

TEAC



AD-RW900

CD Recorder/Reverse Cassette Deck

OWNER'S MANUAL

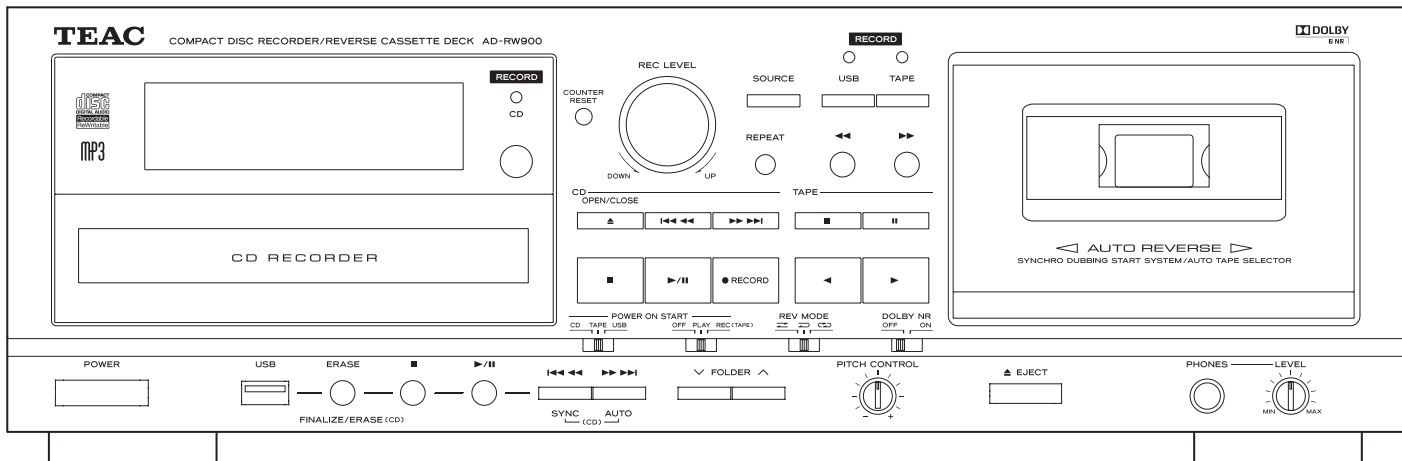

	CAUTION RISK OF ELECTRIC SHOCK DO NOT OPEN	
CAUTION: TO REDUCE THE RISK OF ELECTRIC SHOCK, DO NOT REMOVE COVER (OR BACK). NO USER-SERVICEABLE PARTS INSIDE. REFER SERVICING TO QUALIFIED SERVICE PERSONNEL.		



The lightning flash with arrowhead symbol, within an equilateral triangle, is intended to alert the user to the presence of uninsulated "dangerous voltage" within the product's enclosure that may be of sufficient magnitude to constitute a risk of electric shock to persons.



The exclamation point within an equilateral triangle is intended to alert the user to the presence of important operating and maintenance (servicing) instructions in the literature accompanying the appliance.

IMPORTANT SAFETY INSTRUCTIONS

- 1) Read these instructions.
- 2) Keep these instructions.
- 3) Heed all warnings.
- 4) Follow all instructions.
- 5) Do not use this apparatus near water.
- 6) Clean only with dry cloth.
- 7) Do not block any ventilation openings. Install in accordance with the manufacturer's instructions.
- 8) Do not install near any heat sources such as radiators, heat registers, stoves, or other apparatus (including amplifiers) that produce heat.
- 9) Do not defeat the safety purpose of the polarized or grounding-type plug. A polarized plug has two blades with one wider than the other. A grounding type plug has two blades and a third grounding prong. The wide blade or the third prong are provided for your safety. If the provided plug does not fit into your outlet, consult an electrician for replacement of the obsolete outlet.
- 10) Protect the power cord from being walked on or pinched particularly at plugs, convenience receptacles, and the point where they exit from the apparatus.
- 11) Only use attachments/accessories specified by the manufacturer.
- 12) Use only with the cart, stand, tripod, bracket, or table specified by the manufacturer, or sold with the apparatus. When a cart is used, use caution when moving the cart/apparatus combination to avoid injury from tip-over.
- 13) Unplug this apparatus during lightning storms or when unused for long periods of time.
- 14) Refer all servicing to qualified service personnel. Servicing is required when the apparatus has been damaged in any way, such as power-supply cord or plug is damaged, liquid has been spilled or objects have fallen into the apparatus, the apparatus has been exposed to rain or moisture, does not operate normally, or has been dropped.



- Do not expose this apparatus to drips or splashes.
- Do not place any objects filled with liquids, such as vases, on the apparatus.
- Do not install this apparatus in a confined space such as a book case or similar unit.
- The apparatus draws nominal non-operating power from the AC outlet with its POWER or OFF/ON switch not in the ON position.
- The apparatus should be located close enough to the AC outlet so that you can easily grasp the power cord plug at any time.
- The mains plug is used as the disconnect device, the disconnect device shall remain readily operable.
- Products with Class I construction are equipped with a power supply cord that has a grounding plug. The cord of such a product must be plugged into an AC outlet that has a protective grounding connection.
- If the product uses batteries (including a battery pack or installed batteries), they should not be exposed to sunshine, fire or excessive heat.
- CAUTION for products that use replaceable lithium batteries: there is danger of explosion if a battery is replaced with an incorrect type of battery. Replace only with the same or equivalent type.
- Caution should be taken when using earphones or headphones with the product because excessive sound pressure (volume) from earphones or headphones can cause hearing loss.

WARNING: TO PREVENT FIRE OR SHOCK HAZARD, DO NOT EXPOSE THIS APPLIANCE TO RAIN OR MOISTURE.

CAUTION

- DO NOT REMOVE THE EXTERNAL CASES OR CABINETS TO EXPOSE THE ELECTRONICS. NO USER SERVICEABLE PARTS ARE WITHIN.
- IF YOU ARE EXPERIENCING PROBLEMS WITH THIS PRODUCT, CONTACT TEAC FOR A SERVICE REFERRAL. DO NOT USE THE PRODUCT UNTIL IT HAS BEEN REPAIRED.
- USE OF CONTROLS OR ADJUSTMENTS OR PERFORMANCE OF PROCEDURES OTHER THAN THOSE SPECIFIED HEREIN MAY RESULT IN HAZARDOUS RADIATION EXPOSURE.

IN NORTH AMERICA USE ONLY ON 120 V SUPPLY.

Supply of this product does not convey a license nor imply any right to distribute MPEG Layer-3 compliant content created with this product in revenue-generating broadcast systems (terrestrial, satellite, cable and/or other distribution channels), streaming applications (via Internet, intranets and/or other networks), other content distribution systems (pay-audio or audio-on-demand applications and the like) or on physical media (compact discs, digital versatile discs, semiconductor chips, hard drives, memory cards and the like). An independent license for such use is required. For details, please visit <http://mp3licensing.com>.

MPEG Layer-3 audio coding technology licensed from Fraunhofer IIS and Thomson.

Manufactured under license from Dolby Laboratories. Dolby and the double-D symbol are trademarks of Dolby Laboratories.

This product is protected by certain intellectual property rights of Microsoft. Use or distribution of such technology outside of this product is prohibited without a license from Microsoft.

Other company names, product names and logos in this document are the trademarks or registered trademarks of their respective owners.

For U.S.A.

This equipment has been tested and found to comply with the limits for a Class B digital device, pursuant to Part 15 of the FCC Rules. These limits are designed to provide reasonable protection against harmful interference in a residential installation. This equipment generates, uses, and can radiate radio frequency energy and, if not installed and used in accordance with the instructions, may cause harmful interference to radio communications. However, there is no guarantee that interference will not occur in a particular installation. If this equipment does cause harmful interference to radio or television reception, which can be determined by turning the equipment off and on, the user is encouraged to try to correct the interference by one or more of the following measures:

- Reorient or relocate the equipment and/or the receiving antenna.
- Increase the separation between the equipment and receiver.
- Connect the equipment into an outlet on a circuit different from that to which the receiver is connected.
- Consult the dealer or an experienced radio/TV technician for help.

CAUTION
Changes or modifications to this equipment not expressly approved by TEAC CORPORATION for compliance will void the user's warranty.

This product has been designed and manufactured according to FDA regulations "title 21, CFR, chapter 1, subchapter J, based on the Radiation Control for Health and Safety Act of 1968", and is classified as class 1 laser product. There is not hazardous invisible laser radiation during operation because invisible laser radiation emitted inside of this product is completely confined in the protective housings. The label required in this regulation is as follows:

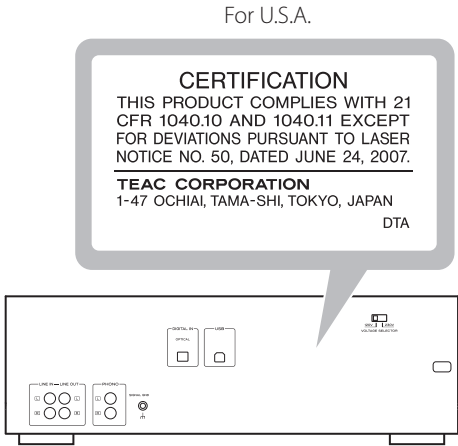

Optical pickup
 Type: SF-DS1XD
 Manufacturer: SANYO ELECTRIC CO., LTD.
 Laser output: Less than 1.6 mW (Play) on the objective lens
 Less than 47 mW (Record) on the objective lens
 Less than 13 mW (Erase) on the objective lens
 Wavelength: 785 nm

For European customers

Disposal of electrical and electronic equipment

- (a) All electrical and electronic equipment should be disposed of separately from the municipal waste stream via collection facilities designated by the government or local authorities.
- (b) By disposing of electrical and electronic equipment correctly, you will help save valuable resources and prevent any potential negative effects on human health and the environment.
- (c) Improper disposal of waste electrical and electronic equipment can have serious effects on the environment and human health because of the presence of hazardous substances in the equipment.
- (d) The Waste Electrical and Electronic Equipment (WEEE) symbol, which shows a wheeled bin that has been crossed out, indicates that electrical and electronic equipment must be collected and disposed of separately from household waste. 
- (e) Return and collection systems are available to end users. For more detailed information about the disposal of old electrical and electronic equipment, please contact your city office, waste disposal service or the shop where you purchased the equipment.

Disposal of batteries and/or accumulators

- (a) Waste batteries and/or accumulators should be disposed of separately from the municipal waste stream via collection facilities designated by the government or local authorities.
- (b) By disposing of waste batteries and/or accumulators correctly, you will help save valuable resources and prevent any potential negative effects on human health and the environment.
- (c) Improper disposal of waste batteries and/or accumulators can have serious effects on the environment and human health because of the presence of hazardous substances in them.
- (d) The WEEE symbol, which shows a wheeled bin that has been crossed out, indicates that batteries and/or accumulators must be collected and disposed of separately from household waste. 
Pb, Hg, Cd
If a battery or accumulator contains more than the specified values of lead (Pb), mercury (Hg), and/or cadmium (Cd) as defined in the Battery Directive (2006/66/EC), then the chemical symbols for those elements will be indicated beneath the WEEE symbol.
- (e) Return and collection systems are available to end users. For more detailed information about the disposal of waste batteries and/or accumulators, please contact your city office, waste disposal service or the shop where you purchased them.

Contents

Thank you for choosing this TEAC product. Read this manual carefully to get the best performance from this unit.

What You Can Do with This Unit	5
Before Use	6
Discs	7
USB Flash Drives	8
MP3 Files	9
Cassette Tapes	9
Connections	10
Identifying the Parts (Main Unit)	12
Identifying the Parts (Remote Control Unit)	14
Remote Control Unit	15
Display	16
Basic Operation	18
Listening to a CD	20
Listening to Files on a USB Flash Drive (MP3/WMA)	22
Shuffle Playback	24
Repeat Playback	24
Programmed Playback	25
Listening to a Cassette Tape	28
About Recording	30
Before Recording	31
Recording on a CD	31
Synchronous recording to CD	34
Finalizing	36
Unfinalizing (CD-RW only)	37
Erasing tracks from a disc (CD-RW only)	38
Recording on a USB Flash Drive	39
Erasing Files from a USB Flash Drive	42
Recording on a Cassette Tape	42
Timer-Controlled Playback and Recording	45
Recording to a Computer	48
Troubleshooting	49
MP3 Playback Order	50
Specifications	51

What You Can Do with This Unit

Playback

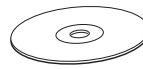

**CD/CD-R/CD-RW
(Audio CD/MP3/WMA disc)**

➔ "Listening to a CD" on pages 20-21

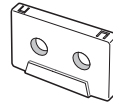

Cassette tape

➔ "Listening to a Cassette Tape" on pages 28-30



MP3/WMA files on USB flash drive

➔ "Listening to Files on a USB Flash Drive (MP3/WMA)" on pages 22-23

Recording

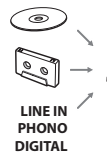

Record on a USB flash drive from a CD, cassette tape or an external device connected to this unit

➔ "Recording on a USB Flash Drive" on pages 39-41



Record on a cassette tape from a CD, USB flash drive or an external device connected to this unit

➔ "Recording on a Cassette Tape" on pages 43-45



Record on a CD from a cassette tape or an external device connected to this unit

➔ "About Recording" on page 30



Record on a computer from a CD, cassette tape, USB flash drive or an external device connected to this unit

➔ "Recording to a Computer" on page 48

Timer operation

Requires a commercially available timer

"Timer-Controlled Playback"

➔ page 46



"Timer-Controlled Recording"

➔ pages 46-47



Before Use

What's in the box

Confirm that the standard accessories are included.

Remote control unit (RC-1283) x 1

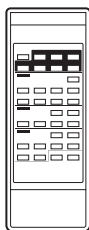

Batteries (AAA) for remote control unit x 2



Stereo RCA pin cable x 2

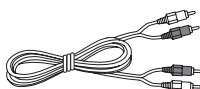

Owner's manual (this document) x 1

- Keep this manual in a safe place for future reference.

Warranty card x 1

CAUTION

- Do not move the unit during CD playback.
During CD playback, the disc rotates at high speed. Do not lift or move the unit during playback. Doing so might damage the disc or the unit.
- The voltage supplied to the unit should match the voltage that is printed on the rear panel. If you are in any doubt regarding this matter, consult an electrician.
- Do not open the cabinet as this might result in damage to the circuitry or electrical shock. If a foreign object should get into the unit, contact your dealer or service company.
- When removing the power plug from the wall outlet, always pull directly on the plug, never yank on the cord.
- Always remove the disc before relocating or moving this unit. Moving the unit with a disc inside it could cause malfunction.

Placement of the unit

- Choose the location where you install the unit carefully. Avoid placing it in direct sunlight or close to a source of heat. You should also avoid locations that are subject to vibrations or exposed to excessive dust, heat, cold or moisture.
- As the unit may become warm during operation, always leave sufficient space around it for ventilation.
- Do not place the unit on an amplifier, a receiver or any other device that generates heat.

- When the unit is turned on, if a TV is turned on nearby lines might appear on the TV screen depending on the frequency of the TV broadcast. This is not a malfunction of the unit or the TV. If you see such lines, move the unit and the TV further apart.

Beware of condensation

When the unit is moved from a cold to a warm place, or used after a sudden temperature change, there is a danger of condensation; vapor in the air could condense on the internal mechanism, making correct operation impossible. To prevent this, or if this occurs, leave the unit turned on for one or two hours. Then the unit will stabilize at the temperature of its surroundings.

Maintenance

If the surface of the unit gets dirty, wipe it with a soft cloth or use diluted mild liquid soap. Allow the surface of the unit to dry completely before using.

⚠ For safety, disconnect the power cord from the outlet before cleaning.

- Never spray liquid directly on this unit.
- Do not use thinner or alcohol as they could damage the surface of the unit.

Cleaning and demagnetizing the cassette deck

Cleaning

A dirty head can cause poor sound quality or the sound to skip. Dirt on the tape tracking roller might catch the tape. Clean the head, pinch roller, and capstan with a cotton applicator dampened with a commercially available cleaning solution about every ten hours of use.

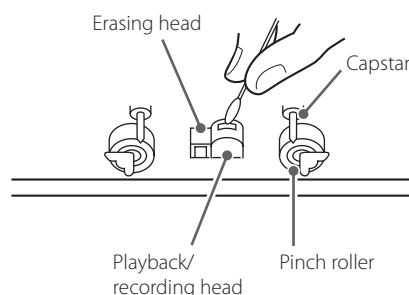

Demagnetizing

When the head is magnetized, it increases noise and hinders the transmission of high notes.

If these problems occur, demagnetize the head using a commercially available head eraser.

- Do not put a cassette tape in the cassette holder of the unit until the cleaning solution on the head dries.

Discs that can be played by this unit

CDs (12-cm and 8-cm) that bear the "COMPACT disc DIGITAL AUDIO" logo can be played by this unit.



- The logo should be on the disc label or the CD jacket.

CD-R and CD-RW discs that have been correctly recorded in the audio CD format and finalized, as well as finalized CD-R and CD-RW discs that contain MP3 or WMA files, can be played by this unit.

This unit can play these types of discs without an adapter. It cannot play any other type of disc.

⚠ Playback of any other type of disc could cause loud noise and damage to speakers as well as harm hearing. Never try to play any other type of disc.

- Depending on the quality of the disc and/or the condition of the recording, some discs might not be playable.
- This unit cannot read or playback the following types of discs: video CDs, CD-ROMs, Super Audio CDs, video DVDs, audio DVDs, and DVD-ROMs.

⚠ CAUTION

If you put a video or audio DVD, DVD-ROM or other types of DVD into the disc tray, the unit will attempt to read the disc and rotate at high speed. If you accidentally insert such a disc, wait until the unit stops spinning before ejecting it in order to avoid possibly damaging the disc. Do not attempt to remove the disc when "READING" appears on the display.

- Copy-protected discs and other discs that do not conform to the CD standard might not play correctly with this player. If you use such discs with this unit, TEAC Corporation and its subsidiaries will not be responsible for any consequences or guarantee the quality of reproduction. If you experience problems with such non-standard discs, you should contact their issuers.

Please use CD, CD-R and CD-RW discs bearing the "DIGITAL AUDIO" mark.



- Depending on the quality of the disc and/or the condition of the recording, some CD-R or CD-RW discs may not be playable.

About CD-R/CD-RW discs

This unit can play back CD-R and CD-RW discs that have been recorded in the audio CD format (CD-DA) and the MP3 or WMA format.

- Discs created by a CD recorder must be finalized before use with this unit.
- Depending on disc quality and recording conditions, playback of some discs might not be possible. Please see the manual for the device that you used to create the disc.
- If you are uncertain about the handling of a CD-R or CD-RW disc, please contact the seller of the disc directly.

CAUTION

- Do not play any disc that is warped, deformed or damaged. Playing such discs could cause irreparable harm to the playing mechanisms.
- While printable CD-R and CD-RW discs utilizing modern printing technologies are generally acceptable, older systems that use adhesives to attach paper type labels to the disc surface are not recommended.
- Do not stick paper or protective sheets on discs and do not use any protective coating sprays.
- Never use a stabilizer. Using commercially available CD stabilizers with this unit will damage the mechanisms and cause them to malfunction.
- Do not use irregularly-shaped discs (octagonal, heart-shaped, business card size, etc.). Such CDs could damage the unit.

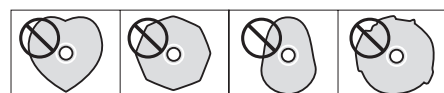

Discs (2)

Handling precautions

- Always place the disc on the disc tray with the label side up. Only one side of a Compact Disc can be played or used for recording.
- Do not touch the signal side (the unlabeled side). Fingerprints, oils and other substances can cause errors during playback.
- To remove a disc from a standard storage case, press down on the case through the center of the disc and lift the disc out, holding it carefully by its edges.

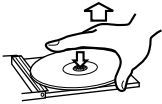

How to remove a disc



How to hold a disc

Storage precautions

- Discs should be returned to their cases after use to avoid dust and scratches that could cause the laser pickup to “skip.”
- Do not expose discs to direct sunlight or high temperature or humidity for extended periods. Long exposure to high temperatures will warp discs.
- CD-R and CD-RW discs are more sensitive to the effects of heat and ultraviolet rays than commercial CDs. It is important that they not be stored in locations where they will be exposed to direct sunlight. They should also be kept away from sources of heat, such as radiators and heat-generating electrical devices.
- To clean the signal side of a disc, wipe gently with a soft dry cloth from the center towards the outside edge. Dirt on discs can lower the sound quality, so clean them and always store them in a clean state.

Maintenance

- If a disc becomes dirty, wipe its surface radially from the center hole outward towards the outer edge with a soft, dry cloth.



- Never clean discs using chemicals such as record sprays, antistatic sprays and fluids and thinners. Such chemicals will do irreparable damage to the disc’s plastic surface.

If you are in any doubt as to the care and handling of a CD-R or CD-RW disc, read the precautions supplied with the disc or contact the disc manufacturer.

USB Flash Drives

⚠ CAUTION

Never turn the unit off or disconnect a USB flash drive when it is being accessed, for example, during writing, playback, recording or the erasure of files.

Doing so could damage the AD-RW900 and the connected USB flash drive.

Compatibility

- Only USB flash drive can be used.
- Some flash memory players that charge from a USB terminal cannot be used for playback.
- Hard disk drives, CD/DVD drives, and other devices connected via USB cannot be used.
- This unit cannot copy or move files.
- Playable formats: FAT12, FAT16, FAT32
- NTFS, HFS and HFS+ formats cannot be used.
- Max. number of playable folders: 255
- Max. number of playable/recordable files: 999
- Depending on the conditions of a USB flash drive, this unit might not be able to play the files on it or skipping might occur.

Recording

This unit can record sound from CDs, cassette tapes and connected external devices, including tuners, to USB flash drives in MP3 format. See page 39 for details.

MP3 Files

This unit can play MP3 files that are on CD-R/CD-RW discs and external USB flash drives.

- This unit can play back mono and stereo MP3 files that are in the MPEG-1 Audio Layer 3 format with a sampling rate of 16-48 kHz and a bit rate of 320 kbps or less.
- This unit is not compatible with discs that have been recorded using multiple sessions. Only the first session can be played back.
- See page 39 for information about the file format recorded on USB flash drives using this unit.

File information display

The display of this unit can only show single-byte letters and numbers.

- If the file information uses Japanese, Chinese or other double-byte characters, playback is possible but the name will not be shown correctly. In such cases, "****" is displayed.

Precautions when preparing MP3 files using a computer or other device

- Always include the extension in the file name. This unit recognizes MP3 files by their ".mp3" file extensions.
- Always close the session (complete disc creation). This unit cannot play discs if the session has not been closed.
- Carefully read the manual for the software that you are using when you create an MP3 disc.

Files that are unplayable or only partially playable

- Files without extensions cannot be played. Files that are not in the MP3 format cannot be played even if they have ".mp3" file extensions.
- Variable bit rate files might not play back correctly.
- If the media has more than 999 files or 255 folders, this unit cannot play any file in a folder that is 256th or later or any file that is the 1000th or later in a folder.
- Depending on disc conditions, this unit might not be able to play a disc or skipping might occur.

Cassette Tapes (1)

Tape types

There are several types of cassette tapes.

Cassette tapes that can be played by this unit

Normal (type I) Chrome (type II) Metal (type IV)

Cassette tapes that can be recorded on by this unit

Normal (type I) Chrome (type II)

CAUTION

- Do not open a cassette or pull out the tape.
- Do not touch the tape.

Storage precautions

- Keep cassette tapes away from magnets or magnetized items because they may cause noise or erase recorded contents.
- Do not leave cassette tapes in a dusty place.
- Do not store cassette tapes in a place with high temperature or humidity.

Types of cassette tapes that should be avoided

The following types of cassette tapes might prevent the unit from operating or functioning normally. The tape of such cassette tapes could be caught in the unit and cause unexpected problems.

Deformed cassette tapes

Cassettes that are deformed, that have tape that does not track properly, or that generate abnormal noise during fast-forwarding or rewinding.

Long-duration tapes

Tapes that allow recording for 90 minutes or longer sometimes get caught by the capstan because they are extremely thin and stretch easily. Avoid using them whenever possible.

Slackening of tapes

Slack tape could get caught in the capstan or other parts. Eliminate slack by using a pencil or similar tool before use.

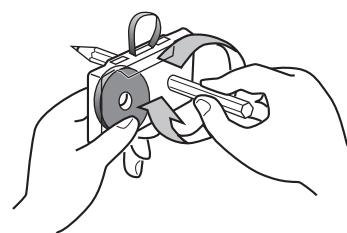

Cassette Tapes (2)

Automatic tape type detection function

This cassette deck can detect what type of tape is being used based on the detection holes in the cassette shell. Be sure to use cassettes with detection holes.

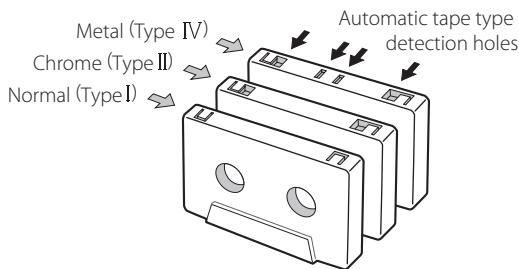

Accidental erasure prevention tabs

Tabs in the top of the cassette shell allow you to prevent important recordings from being erased by mistake. There are two tabs in each cassette shell—one for "side A" and one for "side B."

Once these tabs have been removed using a screwdriver or similar tool, there is no chance of the recording function being activated by accident.

Accidental erasure prevention tab for "side A"

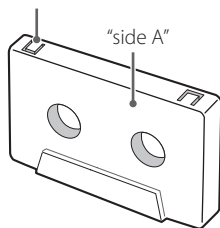

- To record on a cassette that has had its tab broken off, cover the hole using a piece of adhesive tape. Be careful not to block the tape type detection holes.

Dolby NR (noise reduction)

Dolby NR is designed to reduce tape hiss, which is noise introduced during the recording and playback processes. This cassette deck is equipped with Dolby B-type noise reduction.

Use the DOLBY NR switch to turn the Dolby NR on and off.

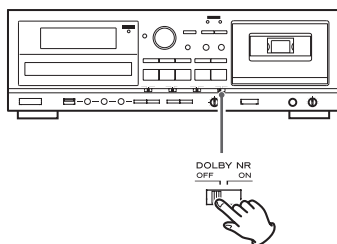

- The Dolby NR system affects both recording and playback quality. For playback, be sure to set the DOLBY NR switch to the same position used when the recording was made.

Connections

Voltage Selection

(General export/North America models only)

⚠ Be sure to remove the power cord from the AC outlet before changing the position of the voltage selector switch.

1. Locate the VOLTAGE SELECTOR switch on the rear panel.
2. Using a flat-bladed screwdriver, set it to the appropriate position (230 V or 120 V) for the power supply used in your area.

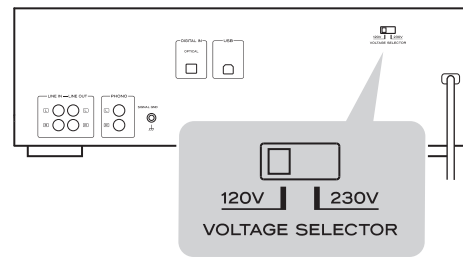

IN NORTH AMERICA USE ONLY ON 120 V SUPPLY.

Notes on turning on or off the power

When an amplifier is connected to the AD-RW900, turn on or off the power of the AD-RW900 and the amplifier in the following sequence.

When turning on the power

1. AD-RW900
2. Amplifier

When turning off the power

1. Amplifier
2. AD-RW900

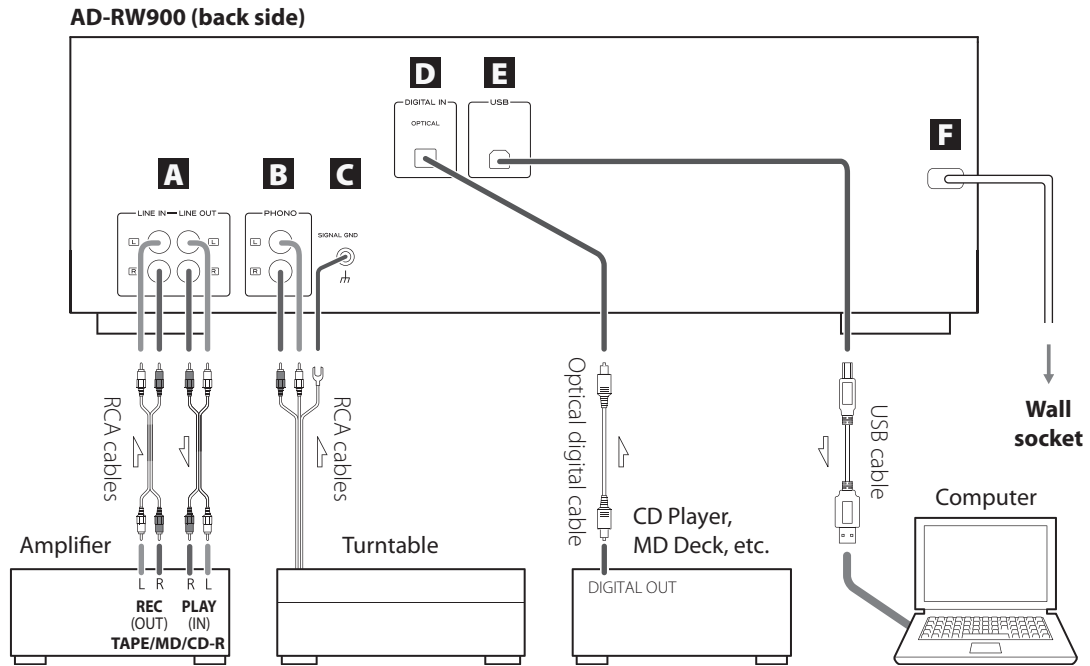

⚠ After all connections are complete, connect the power cord's plug to the AC wall socket.

- Read the instructions of each device that you intend to use with this unit.
- Be sure to connect each plug securely. To avoid hum and noise, do not bundle the connection cords.

A LINE IN/OUT jacks

These jacks transmit an analog 2-channel audio signal. Connect the components using the included RCA pin cables.

Be sure to connect:

- White plug → White jack** (L: left channel)
- Red plug → Red jack** (R: right channel)



B PHONO jacks [PHONO]

Connect the turntable's RCA pin cable to the PHONO jacks.

Be sure to connect:

- White plug → White jack** (L: left channel)
- Red plug → Red jack** (R: right channel)

- Moving Magnet (MM) cartridges can be used for this unit.

C SIGNAL GND [SIGNAL GND]

Connect the ground lead of the turntable to this terminal.

- This is not a safety earth.
- If the turntable's ground lead is not connected to this terminal, hum noise may be heard.

D DIGITAL IN terminal [DIGITAL IN]

To record digital audio signals, connect this terminal to the digital output terminal of a digital device such as a CD player with a commercially available optical digital cable.

If the sampling frequency of the input digital signal is changed while an optical digital cable is connected, it might not be recognized correctly. ("OPTICAL UNLOCK" will appear on screen.) If this occurs, disconnect the optical digital cable from the connector once and reconnect it after changing the frequency. Alternately, after changing the frequency, you can turn the power off once and then turn it on again.

E USB port (B-type) [USB]

Connect this to a computer USB port to convert sound from this unit to a digital signal and output it to the computer.

F AC Power Cord

After all other connections are complete, connect the plug to an AC wall outlet.

⚠ If you do not use this unit for a long period of time, unplug the power cord from the wall outlet.

⚠ Be sure to connect the power cord to an AC outlet that supplies the correct voltage.

⚠ Hold the power plug when plugging it into an outlet or unplugging it. Never pull or yank on the power cord.

Identifying the Parts (Main Unit)

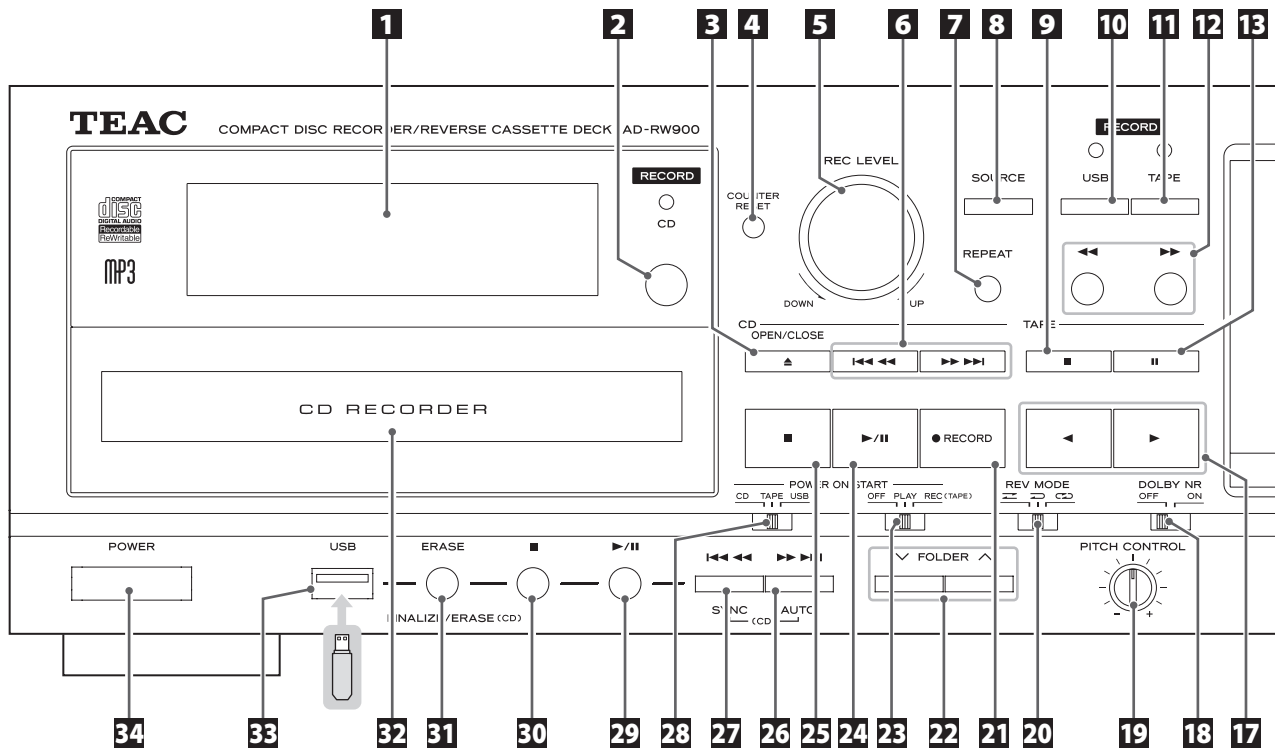

1 Display

See "Display" on pages 16-18.

2 Remote sensor

When operating the remote control, point it towards here.

3 CD OPEN/CLOSE (▲)

Press this button to open and close the disc tray.

4 TAPE COUNTER RESET

Press this button to reset the tape counter to "0000".

5 REC LEVEL knob

Turn this knob to adjust the recording level.

- Use to adjust the sound level output to a connected computer except when in recording standby or during recording.

6 CD Skip (I◀◀/▶▶I)/Search (◀◀/▶▶)

Press these buttons to skip through tracks/files.
Hold down these buttons during playback to search for part of a track/file.

7 CD USB REPEAT

Use this button to set the repeat function (page 24).

8 SOURCE

Use this button to select the source (page 19).

9 TAPE Stop (■)

Press this button to stop cassette tape playback.
Press this button to stop recording to a tape.

10 RECORD USB

Use to record to an external USB flash drive. Press it once to enable recording standby, and press it again to start recording (pages 39-40).
Press it during recording to divide the file at that point (page 41).
(When recording from a CD, however, files cannot be divided.)

11 RECORD TAPE

Use to record to a tape. Press it once to enable recording standby, and press it again to start recording (pages 43-44).

12 TAPE Fast-forward/Rewind (◀◀/▶▶)

Press these buttons to fast-forward/rewind the cassette tape.

13 TAPE Pause (II)

Press this button to pause cassette tape playback or recording.
Press this button again to resume playback or recording.

14 TAPE Cassette tape compartment

15 PHONES jack/LEVEL knob

To listen with headphones, turn the LEVEL knob to minimize the volume level before connecting the headphones plug to the PHONES jack. Then, adjust the volume after connecting the plug.

⚠ CAUTION

Do not connect headphones to the PHONES jack while wearing them. Moreover, do not disconnect headphones or turn the unit on or off while wearing them. Very loud sound could be output from the headphones. AVOID DAMAGING YOUR HEARING—Do not put on headphones until after plugging them in.

16 TAPE EJECT (▲)

When the tape is stopped, press this button to open the cassette tape compartment.

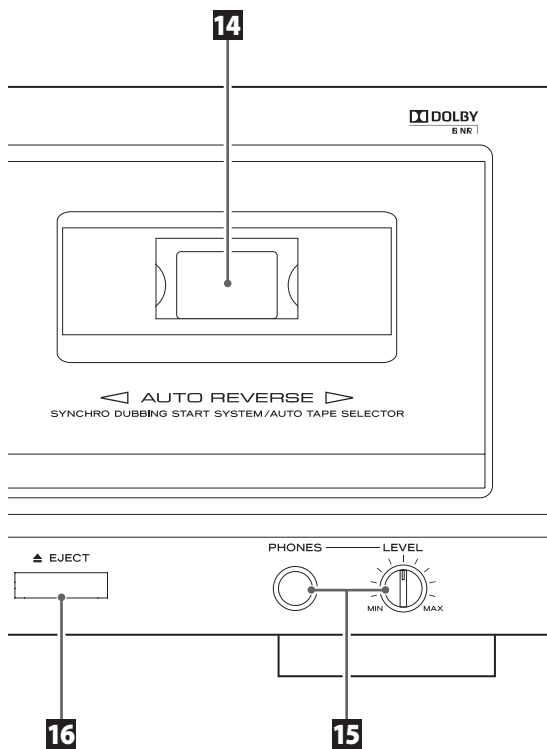

17 TAPE Reverse/Forward play (◀/▶)

Press these buttons to start playback of the back (◀)/front (▶) side of a tape.
Press during tape playback/recording standby to restart playback/recording.

18 TAPE DOLBY NR switch

Use this switch to turn Dolby noise reduction on and off (pages 10 and 28).

19 TAPE PITCH CONTROL knob

Turn this knob to vary the playback speed (page 30).

20 TAPE REV (Reverse) MODE switch

Use this switch to select the reverse mode (page 28).

21 CD RECORD (●)

Use to record to a CD. Press once to enter recording standby, and press again to start recording (page 32-33).
Press this button during recording to add a track number in the song (page 34).

22 CD USB FOLDER (∨/∧)

Use these buttons to select folders (pages 21 and 23).

23 POWER ON START OFF-PLAY-REC (TAPE)

Use this switch to select the timer setting (play, record or off).
To use this when set to play or record, connect a commercially available audio timer to this unit (pages 45-47).

24 CD Play/Pause (▶/||)

Press this button during playback or recording of a CD to pause.
Press this button again to resume playback or recording.
Use also to start finalizing, unfinalizing and erasure.

25 CD Stop (■)

Press this button to stop CD playback.
Press this button also to stop recording to CD.

**26 USB Skip (▶▶|)/Search (▶▶▶)
CD Auto (AUTO)**

When in USB mode, press this button to skip to the next track.
Press and hold this button during playback to search forward.
When recording to a CD, press this button to change how numbers are added to tracks (page 31).

**27 USB Skip (◀◀|)/Search (◀◀◀)
CD Sync (SYNC)**

When in USB mode, press this button to skip to the previous track.
Press and hold this button during playback to search backward.
When recording to a CD, press this button to change the sync recording mode (one track or all tracks) (pages 34-35).

28 POWER ON START CD-TAPE-USB

Use this switch to set the sound source that is active when the power is turned on.
Use this switch to set the media used for timer playback/recording. (The timer recording can only record to cassette tape.)
To use timer playback/recording, connect a commercially available audio timer to this unit (pages 45-47).

29 USB Play/Pause (▶/||)

Press this button during USB flash drive playback or recording to pause.
Press again to resume playback or recording.

30 USB Stop (■)

Press this button to stop USB playback.
Press this button also to stop recording to USB.

**31 USB Erase (ERASE)
CD Finalize/Erase (FINALIZE/ERASE)**

When in USB mode, use to erase files from the USB flash drive (page 42).
When in CD mode, use to finalize a recorded CD-R/CD-RW, and to erase recorded songs on or unfinalize a CD-RW (pages 36-38).

32 CD Disc tray

33 USB USB port (A-type)

Connect an external USB flash drive here.

34 POWER

Press this button to turn the unit on or off.

⚠ CAUTION
Never turn the unit off or disconnect a USB flash drive when it is being accessed, for example, during writing, playback, recording or the erasure of files. Doing so could damage the AD-RW900 and the connected USB flash drive.

⚠ CAUTION
Never turn the unit off when it is writing to a CD (recording, finalizing, unfinalizing, deleting a track). Doing so could result in the disc being unplayable or damage the AD-RW900.

Identifying the Parts (Remote Control Unit)

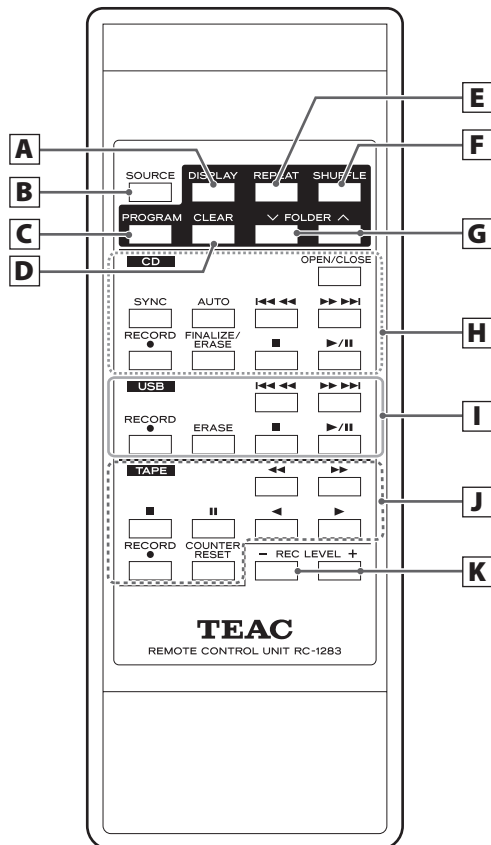

To simplify explanations, instructions in this manual might refer only to the main unit or the remote control. In such cases, the same controls on the remote control and main unit will operate similarly.

A CD USB DISPLAY

Press this button to change the display information (pages 16-18).

B SOURCE

Use this button to select a source (page 19).

C CD USB PROGRAM

Use this button to program tracks/files (pages 25-27).

D CD USB CLEAR

Use this button to clear programmed tracks/files (page 27).

E CD USB REPEAT

Use this button to set the repeat function (page 24).

F CD USB SHUFFLE

Use this button to start shuffle playback (page 24).

G CD USB FOLDER (▼/▲)

Use these buttons to select MP3 folders (pages 21-23).

H CD OPEN/CLOSE (▲)

Press this button to open and close the disc tray.

SYNC

When recording to a CD, press to change the sync recording mode (one track or all tracks) (pages 34-35).

AUTO

When recording to a CD, press to change how numbers are added to tracks (page 31).

Skip (◀◀/▶▶)/Search (◀◀/▶▶)

Press these buttons to skip through tracks/files.

Hold down these buttons during playback to search for part of a track/file.

RECORD (●)

Use to record to a CD. Press once to enter recording standby, and press again to start recording (pages 32-33).

Press during recording to add a track number in the middle of a song (page 34).

FINALIZE/ERASE

When in CD mode, use to finalize a recorded CD-R/CD-RW, and to erase recorded songs on or unfinalize a CD-RW (pages 36-38).

Stop (■)

Press this button to stop CD playback.

Press this button also to stop recording to CD.

Play/Pause (▶/||)

Press this button during playback or recording of a CD to pause.

Press this button again to resume playback or recording.

Use also to start finalizing, unfinalizing and erasure.

I **USB**

Skip (◀◀/▶▶)/Search (◀◀/▶▶)

Press these buttons to skip through files.

Hold down these buttons during playback to search for a part of a file.

RECORD (●)

Use this to record to an external USB flash drive. Press it once to enable recording standby, and press it again to start recording (pages 39-40).

Press it during recording to divide the file at that point (page 41). (When recording from a CD, however, files cannot be divided.)

ERASE

Use this button to erase files from a USB flash drive (page 42).

Stop (■)

Press this button to stop playback.

Press this button to stop recording to USB.

Play/Pause (▶/||)

Press this button during USB flash drive playback or recording to pause.

Press again to resume playback or recording.

J **TAPE**

Fast-forward/Rewind (◀◀/▶▶)

Press these buttons to fast-forward/rewind the tape.

Stop (■)

Press this button to stop playback.

Press this button to stop recording to a tape.

Pause (||)

Press this button to pause playback or recording.

Press this button again to resume playback or recording.

Reverse/Forward play (◀/▶)

Press these buttons to start playback of the back (◀)/front (▶) side of a tape.

Press during tape playback/recording standby to restart playback/recording.

RECORD (●)

Use to record to a tape. Press it once to enable recording standby, and press it again to start recording (pages 43-44).

COUNTER RESET

Press this button to reset the tape counter to "0000".

K **REC LEVEL (-/+)**

Use these buttons to adjust the recording level. Use these buttons as well to adjust the sound level output to a connected computer except when in recording standby or during recording.

The included remote control allows this unit to be operated from a distance.

When using the remote control, point it towards the remote sensor on the front panel of the main unit.

- Even if the remote control unit is used within its effective range, operation by remote control might not be possible if there are any obstacles between the unit and the remote control.
- If direct sunlight or strong artificial illumination shines on the remote sensor, the remote control might not function. If that is the case, move this unit to another location.

Battery installation

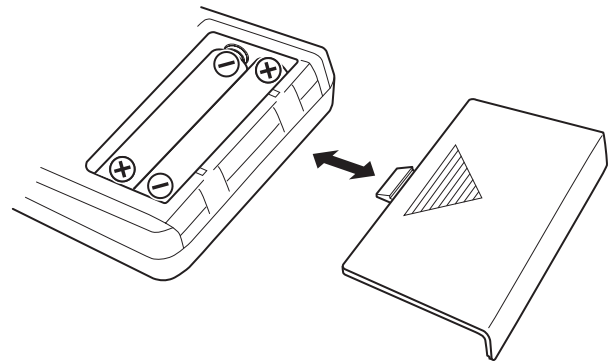

1. Remove the battery compartment cover.
2. Insert two AAA (R03) dry batteries. Make sure that they are inserted with their positive (+) and negative (-) poles oriented correctly.
3. Close the cover.

Battery replacement

If the distance from the main unit that the remote control works effectively decreases, the batteries are probably exhausted. Replace the batteries with new ones when this happens.

For more information about the collection of batteries, please contact your local municipality, your waste disposal service or the place where you purchased them.

Remote Control Unit (2)

Precautions concerning batteries

- ⚠ Misuse of batteries could cause them to rupture or leak leading to fire, injury or the staining of nearby things. Please read and observe the following precautions carefully.
- Be sure to insert the batteries with correct positive (⊕) and negative (⊖) orientations.
- Use batteries of the same type. Never use different types of batteries together.
- Both rechargeable and non-rechargeable batteries can be used. Refer to the precautions on their labels.
- If the remote control will not be used for a long time (more than a month), remove the batteries to prevent them from leaking.
- If the batteries leak, wipe away the leakage inside the battery compartment and replace the batteries with new ones.
- Do not use batteries of types other than those specified. Do not mix new batteries with old ones or use different types of batteries together.
- Do not heat or disassemble batteries.
- Never throw batteries into fire or water.
- Do not carry or store batteries with other metallic objects. The batteries could short circuit, leak or explode.
- Never try to recharge a battery unless you can confirm that it is a rechargeable type.

Display (1)

CD mode

During playback

Audio CD

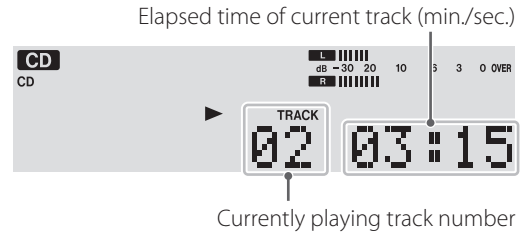

MP3 disc

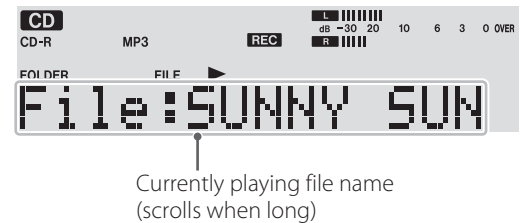
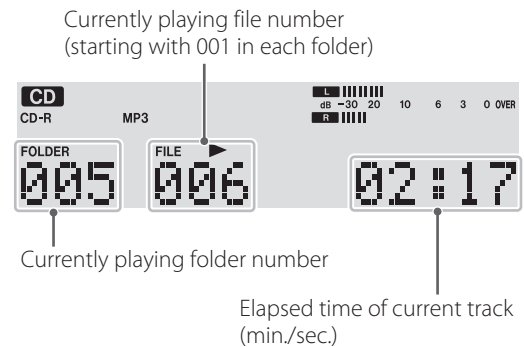

When playback is stopped

Audio CD

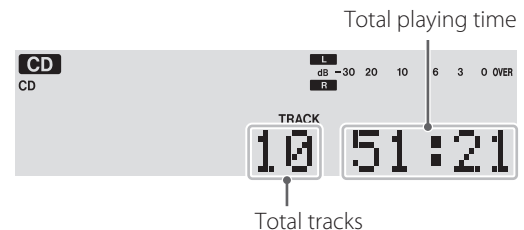

MP3 disc

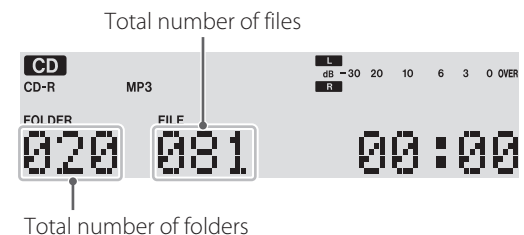

TAPE mode



Tape counter

USB mode

During playback

Currently playing file number
(starting with 001 in each folder)

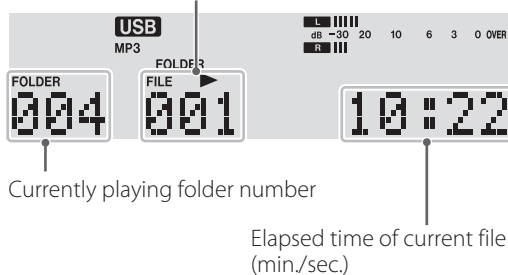

Currently playing folder number

Elapsed time of current file
(min./sec.)

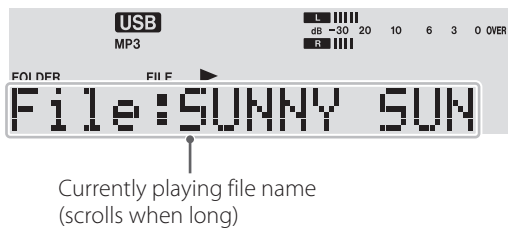

Currently playing file name
(scrolls when long)

When playback is stopped

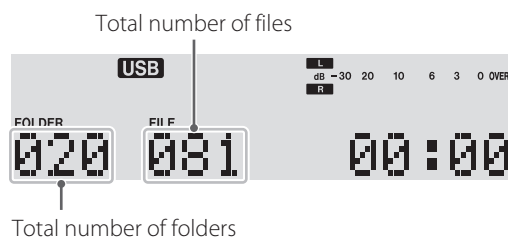

Total number of folders

Recording mode

(Example: Recording on a cassette tape from a USB flash drive)

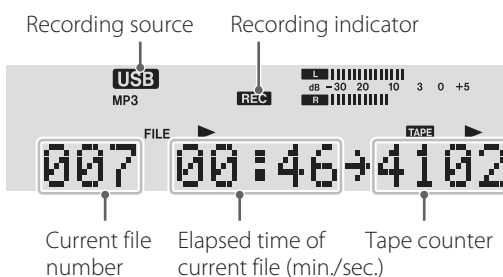

Current file number

Elapsed time of current file
(min./sec.)

Tape counter

(Example: Recording from a file of more than 100 minutes in length)

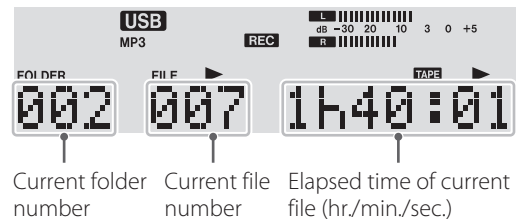

Current folder number

Current file number

Elapsed time of current file
(hr./min./sec.)

(Example: Recording on a CD from a cassette tape)

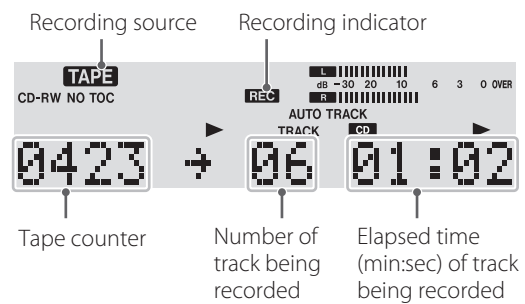

Tape counter

Number of track being recorded

Elapsed time
(min:sec) of track being recorded

(Example: Recording on a CD from an external device connected to the PHONO jacks.)

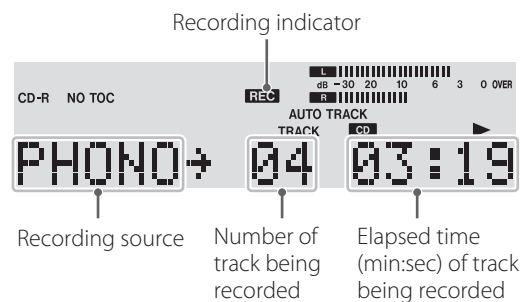

Recording source

Number of track being recorded

Elapsed time
(min:sec) of track being recorded

(Example: Recording on a USB flash drive from a CD)

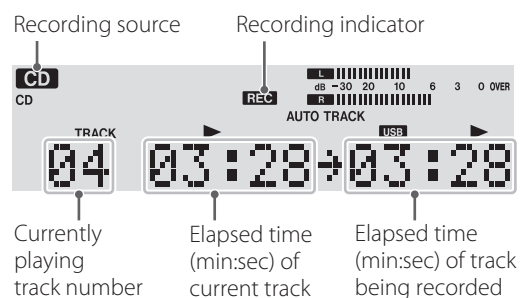

Currently playing track number

Elapsed time
(min:sec) of current track

Elapsed time
(min:sec) of track being recorded

Display (2)

Changing the display (CD/USB mode)

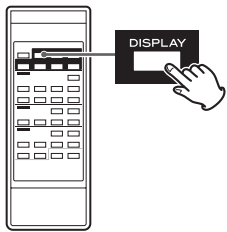

During playback in CD mode or USB mode, each time the DISPLAY button is pressed, the display changes as follows:

Audio CD

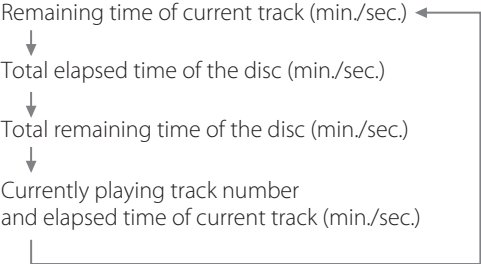

MP3 disc/USB

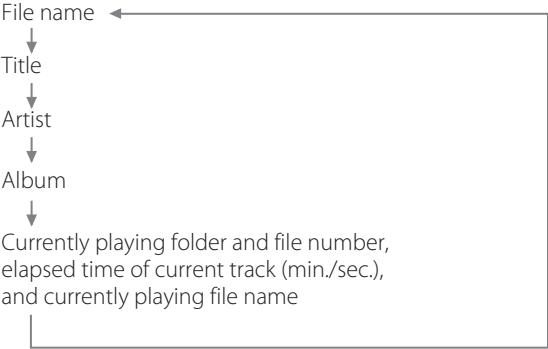

- "Title No" (title information unavailable), "Album No" (album information unavailable) or "Artist No" (artist information unavailable) appears when there is no information.
- "****" appears when the unit cannot read the information.
- The display of this unit can only show single-byte letters and numbers. If a file name uses Japanese, Chinese or other double-byte characters, playback is possible but the name will not be shown correctly. In such cases, "****" is displayed.

Basic Operation

Turning the unit on or off

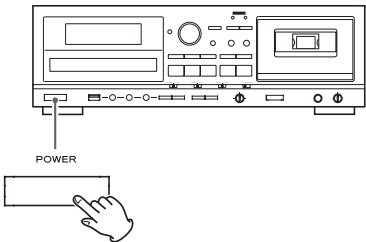

Press the POWER button to turn the unit on or off. When the unit turns on, the display lights.

Check the POWER ON START switches that determine what the unit does when the power is turned on.

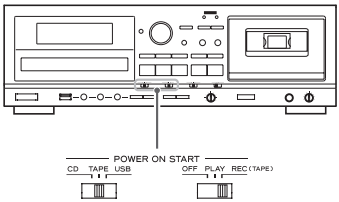

When the power is turned on, and the POWER ON START (OFF-PLAY-REC) switch for the timer is set to PLAY or REC

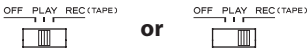

The source set with the POWER ON START (CD-TAPE-USB) switch starts playback/recording.

The timer recording can only record to cassette tape (pages 45-47).

When the power is turned on, and the POWER ON START (OFF-PLAY-REC) switch for the timer is set to OFF



The source set with the POWER ON START (CD-TAPE-USB) switch becomes the active source.

- When you do not want to use the timer, be sure to set the OFF-PLAY-REC switch to the OFF position to prevent accidentally recording over an important cassette tape.

Selecting a source for playback/recording

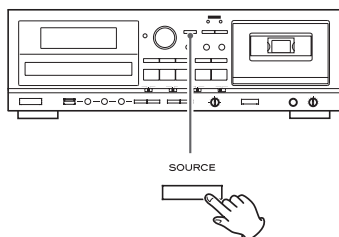

Each time the SOURCE button is pressed, the source changes as follows:



The selected source is shown on the upper left of the display except for PHONO IN, which is shown at the bottom of the display.

- During recording, the source cannot be changed.
- Pressing the play button for a source also selects and starts playback of that source.
- Select "LINE IN" to listen to a source connected to the analog LINE IN jacks.
- Select "PHONO IN" to listen to a record player connected to the PHONO jacks.
- Select "**DIGITAL**" to listen to a digital source connected to the DIGITAL IN terminal.

Listening with headphones

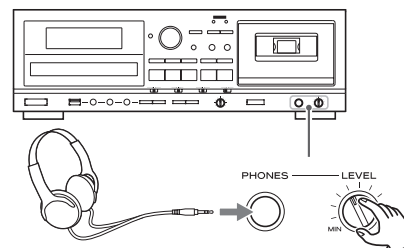

To listen with headphones, turn the LEVEL knob to minimize the volume level before connecting the headphones plug to the PHONES jack. Then, adjust the volume after connecting the plug.

⚠ CAUTION

Do not connect headphones to the PHONES jack while wearing them. Moreover, do not disconnect headphones or turn the unit on or off while wearing them. Very loud sound could be output from the headphones.

AVOID DAMAGING YOUR HEARING—Do not put on headphones until after plugging them in.

Listening to a CD

1 Press the SOURCE button repeatedly to select "CD".

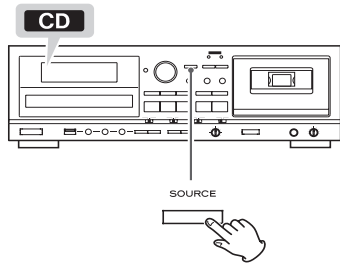

- When a different source is selected, pressing the CD Play/Pause (▶/||) button automatically selects the CD and, if a disc is loaded, starts playback.

2 Press the CD OPEN/CLOSE (▲) button to open the disc tray.

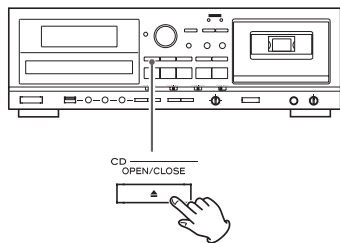

3 Place a disc on the tray with the label side up.

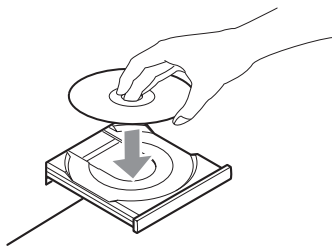

- Always confirm that the disc is centered on the tray. The disc must be centred on the disc tray. If a disc is not correctly loaded, it might not be possible to open the tray again after it has been closed.

CAUTION

- Do not load more than one disc.
- Do not force the tray by hand when opening and closing it.
- Do not attach adhesive labels or similar materials to either side of a disc.
- Do not use irregularly-shaped discs.

Failure to follow any of the above cautions could cause malfunction.

4 Press the CD OPEN/CLOSE (▲) button again to close the tray.

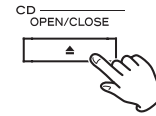

⚠ CAUTION

Be careful not to let your finger be pinched by the tray.

Loading a disc takes a few seconds.

During loading, "READING" appears on the display and no buttons will work. Wait until the total number of tracks/files is displayed.

- When no disc is loaded, "NO DISC" is displayed.

5 Press the CD Play/Pause (▶/||) button to start playback.

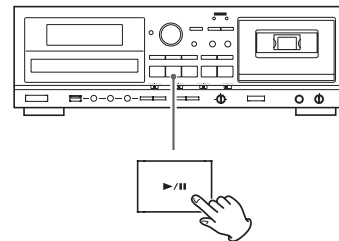

Playback starts from the first track/file on the disc.

- If you load a disc, and then press the CD Play/Pause (▶/||) button without having first closed the disc tray, the disc tray closes and playback starts.
- When playback of all the tracks/files has finished, the unit stops automatically.
- MP3 files that are not placed in folders are automatically put in the "ROOT" folder. Playback starts from the first file in the ROOT folder.
- See page 50 for information about the playback order of MP3 discs.

Suspending playback temporarily (Pause mode)

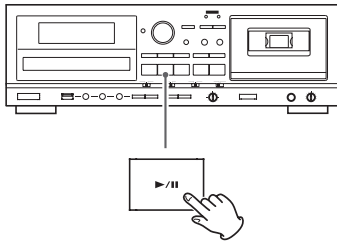

Press the CD Play/Pause (▶/||) button during playback to stop playback at the current position.
To resume playback, press the CD Play/Pause (▶/||) button again .

Stopping playback

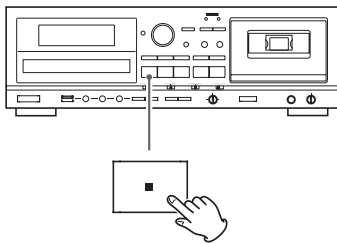

Press the CD Stop (■) button to stop playback.

Opening the disc tray

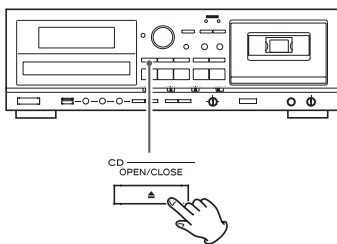

Press the CD OPEN/CLOSE (▲) button to open the disc tray.

- You cannot open the tray when in modes other than CD mode.

Search for a part of a track/file

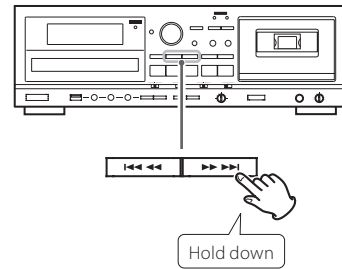

During playback, hold down a CD Search (◀◀ or ▶▶) button to search a part of a track/file. Release it when you find the beginning of the part you want to hear.

Skipping to an earlier or later track/file

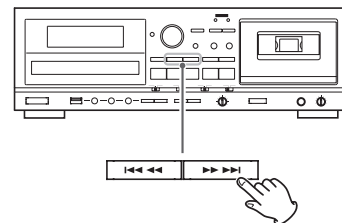

During playback

Press a CD Skip (◀▶ or ▶▶) button repeatedly until the desired track/file is selected. The selected track/file will be played from the beginning.

- If the ◀◀ button is pressed once during playback, the track/file being played will be played again from its beginning. To return to the beginning of the previous track/file, press the ◀◀ button twice.

When playback is stopped or paused

Press a CD Skip (◀▶ or ▶▶) button repeatedly to select the track/file you want to hear. Then, press the CD Play/Pause (▶/||) button to start playback of the selected track/file.

Selecting a folder (MP3/WMA disc)

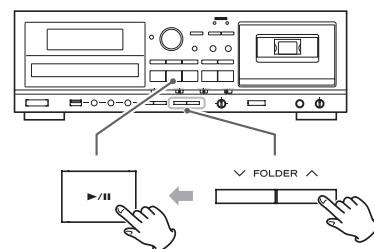

Press a FOLDER (▽ or ▲) button to select a folder. Press the CD Play/Pause (▶/||) button to start playback of the first track in the selected folder.

Listening to Files on a USB Flash Drive (MP3/WMA)

CAUTION

Never turn the unit off or disconnect a USB flash drive when it is being accessed, for example, during writing, playback, recording or the erasure of files. Doing so could damage the AD-RW900 and the connected USB flash drive.

- This section uses MP3 file as an example to explain the operation process; the same process also needs to be followed when WMA file is used.

1 Press the SOURCE button repeatedly to select "USB".

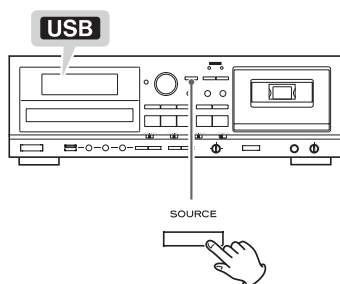

- When a different source is selected, starting USB playback automatically selects the USB mode.

2 Connect an external USB flash drive to the USB port of this unit.

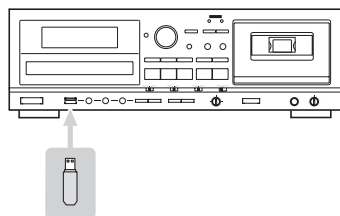

Reading the USB device takes a few seconds.

- If no MP3 file is on the USB device, "NO MUSIC FILE" is displayed.

3 Press the USB Play/Pause (▶/||) button to start playback.

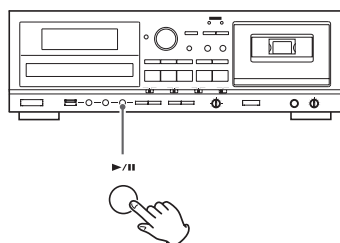

- When playback of all the files has finished, the unit stops automatically.
- MP3 files that are not put in folders are automatically put in the "ROOT" folder. Playback starts from the first file in the ROOT folder.
- See page 50 for information about the playback order of MP3 files.

Pausing playback temporarily

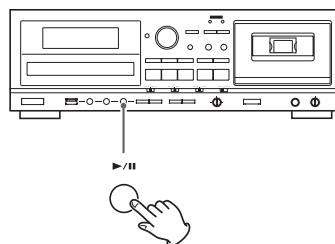

Press the USB Play/Pause (▶/||) button during playback to stop playback at the current position. To resume playback, press the USB Play/Pause (▶/||) button again.

Stopping playback

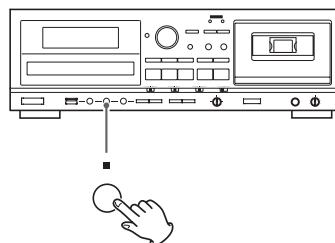

Press the USB Stop (■) button to stop playback.

Search for a part of a file

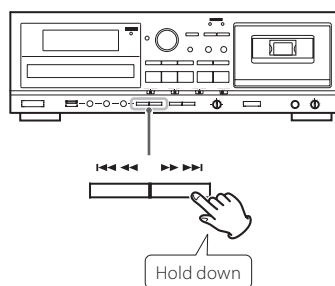

During playback, hold down a USB Search (◀◀ or ▶▶) button to search for a part of a file. Pressing and holding a Search button increases the search speed. Release it when you find the beginning of the part that you want to hear.

Skipping to an earlier or later file

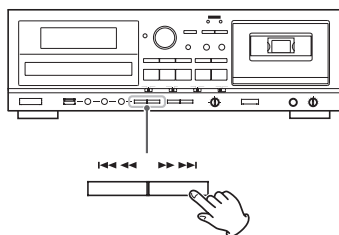

During playback

Press a USB Skip (I<<< or >>>I) button repeatedly until the desired file is selected. The selected file will be played from the beginning.

- If the I<<< button is pressed once during playback, the file being played will be played again from the beginning. To return to the beginning of the previous file, press the I<<< button twice.

When playback is stopped or paused

Press a USB Skip (I<<< or >>>I) button repeatedly to select the file you want to hear. Then, press the USB Play/Pause (▶/||) button to start playback of the selected file.

Selecting a folder

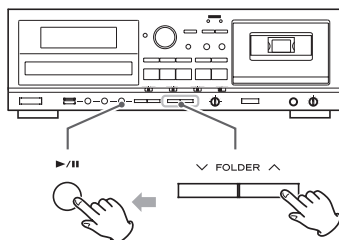

Press a FOLDER (∨ or ∧) button to select a folder. Then, press the USB Play/Pause (▶/||) button to start playback.

Repeat, shuffle and programmed playback

These functions can be used in USB mode.

Please see the following sections for details about using them.

- Shuffle playback** → page 24
- Repeat playback** → page 24
- Programmed playback** → pages 25-27

Shuffle Playback

This function can be used in CD and USB modes.

Use this function to play the tracks/files on a disc/USB flash drive in random order.

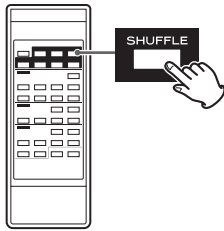

Pressing the SHUFFLE button turns the shuffle mode on and off.

During shuffle playback, "SHUFFLE" appears on the display.

After playing back all tracks/files, the unit exits the "Shuffle" playback mode and stops playback.

To stop shuffle playback, press the CD/USB Stop (■) button.

- If you press the ►► button during shuffle playback, the next track/file will be randomly selected and played. If you press the ◀◀ button, the currently played track/file will be played from the beginning. During shuffle playback, a track/file that has completed playback will not be played again.
- The shuffle function does not work during program playback.
- If any of the following buttons are pressed, shuffle mode will be cancelled.

In CD mode

POWER, SOURCE, CD OPEN/CLOSE (▲), SHUFFLE

In USB mode

POWER, SOURCE, SHUFFLE

Repeat Playback

This function can be used in CD and USB modes.

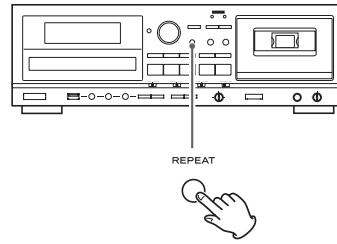

Press the REPEAT button to cycle through the following playback modes:

Audio CD



MP3



- If any of the following buttons are pressed, the repeat mode will be canceled.

In CD mode

POWER, SOURCE, CD OPEN/CLOSE (▲), REPEAT

In USB mode

POWER, SOURCE, REPEAT

- If you press the SHUFFLE button while REPEAT 1 or REPEAT FOLDER is selected, the repeat playback mode will switch to "REPEAT ALL".

REPEAT 1 (Repeat one track/file)

The track/file being played will be played repeatedly. "REPEAT 1" appears on the display.

- If you use a CD/USB Skip (◀◀ or ►►) button to select a different track/file, that track/file will be played repeatedly.
- You can select a track/file to be repeated when playback is stopped. Press the REPEAT button, select a track/file using a CD/USB Skip (◀◀ or ►►) button, and then press the CD/USB Play/Pause (▶/||) button to start playback.

REPEAT ALL (Repeat all tracks/files)

All the tracks/files on the disc will be played repeatedly. "REPEAT ALL" appears on the display.

- During program playback, the programmed tracks/files will be played repeatedly.

REPEAT FOLDER (Repeat all the files in a folder) (MP3 only)

All the files in the selected folder will be played repeatedly. "REPEAT FOLDER" appears on the display.

Programmed Playback (1)

This function can be used in CD and USB modes.

Up to 30 tracks/files can be programmed in the desired order.

- 1** When playback is stopped, press the **PROGRAM** button to enter program mode.

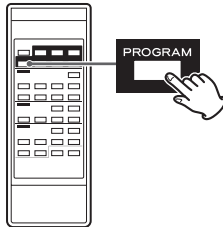

"PROGRAM" blinks and "P-01" appears on the display.

Example when in CD mode



- To stop programming, press the CD/USB Stop (■) button.

- 2** (When programming MP3 files)

Use a CD/USB Skip (◀◀ or ▶▶) button or FOLDER (∨ or ∧) button to select a file, and then press the **PROGRAM** button.

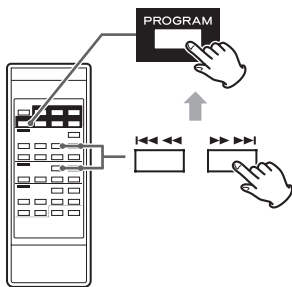

- MP3 files not located in a specific folder are in the "001" (ROOT) folder.

- 3** Press a CD/USB Skip (◀◀ or ▶▶) button to select a track/file, then press the **PROGRAM** button.

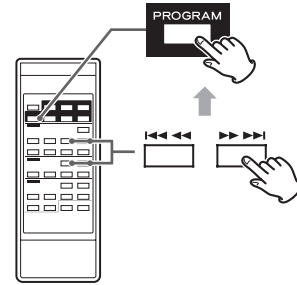

The track/file is programmed, and "P-02" is displayed.

- Repeat steps **2** and **3** to program more tracks/files.
- You can program up to 30 tracks/files.
- To stop programming, press the CD/USB Stop (■) button. Programming is cancelled, but the program contents are retained in memory. If you want to restart program playback, press the **PROGRAM** button, and then press the CD/USB Play/Pause (▶/||) button.

- 4** When the selection of track/file numbers is completed, press the CD/USB Play/Pause (▶/||) button to start program playback.

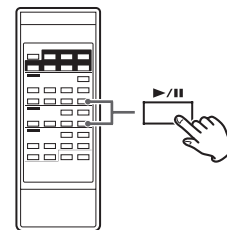

To stop program playback, press the CD/USB Stop (■) button.

- After program playback finishes, press the CD/USB Play/Pause (▶/||) button to play the program again.
- You can use a CD/USB Skip (◀◀ or ▶▶) button during program playback to select and play other tracks/files in the program.
- The shuffle function does not work during program playback.
- "REPEAT 1" and "REPEAT ALL" playback are possible during program playback. When set to "REPEAT ALL" mode, the programmed tracks/files will be played repeatedly.

Programmed Playback (2)

Adding tracks/files to the end of the program

When playback is stopped, press the PROGRAM button repeatedly until "TRACK 00" appears on the display.

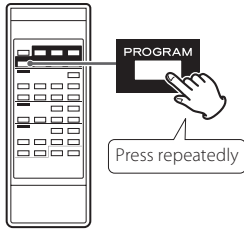

Example:



Select a track/file number you want to add using a CD/USB Skip (I◀◀ or ▶▶I) button, and then press the PROGRAM button.

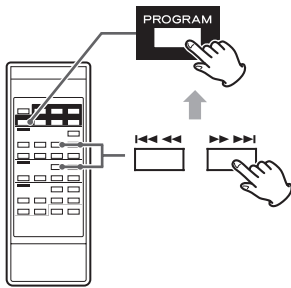

The track/file is added to the end of the program.

Overwriting part of the program

When playback is stopped, press the PROGRAM button repeatedly until the program number of the track that you want to change appears on the display.

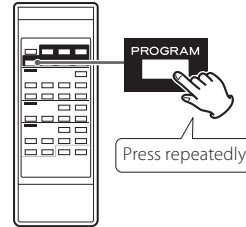

Example:



Program number to be changed

Select the track/file number that you want to add using a CD/USB Skip (I◀◀ or ▶▶I) button, and then press the PROGRAM button.

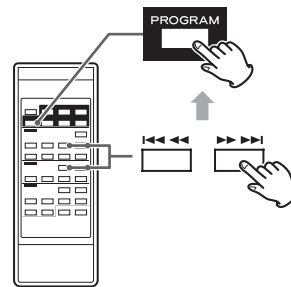

The selected track/file is added to the program, replacing the track that had been at that program number before.

Checking the program order

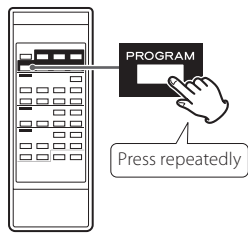

When playback is stopped, press the PROGRAM button repeatedly. The numbers of the programmed tracks/files and their program numbers will be shown in order.

Deleting tracks/files from the program

When playback is stopped, press the PROGRAM button repeatedly **until the program number of the track to be deleted appears** on the display.

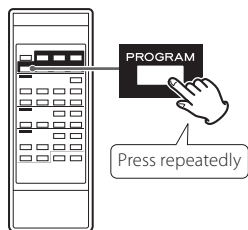

Example:

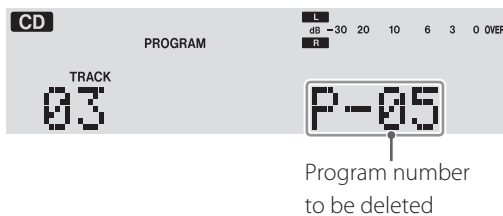

Press the CLEAR button.

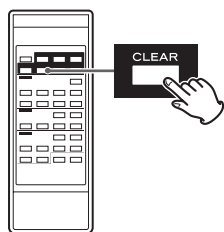

The track/file is deleted from the program.

Clearing the program

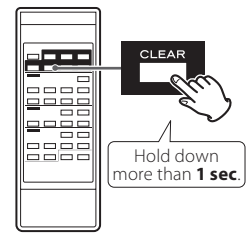

When playback is stopped, press the PROGRAM button, followed by the CLEAR button more than 1 second.

The PROGRAM indicator disappears and all the contents of the program are cleared.

- If the PROGRAM indicator is not shown, press the PROGRAM button to activate program mode before pressing the CLEAR button.
- If one of the following buttons is pressed, the contents of the program are also cleared.

In CD mode

POWER, CD OPEN/CLOSE (▲), SOURCE

In USB mode

POWER, SOURCE

Exiting program mode

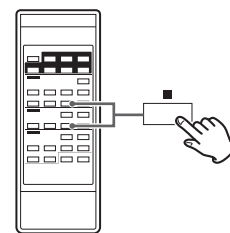

When playback is stopped, press and hold the CD/USB Stop (■) button. The PROGRAM indicator will disappear.

- This does not clear the contents of the program. Press the PROGRAM button again and then press the CD/USB Play/Pause (▶/||) button if you want to restart program playback.

Listening to a Cassette Tape (1)

You can play Normal (type I), Chrome (type II) and Metal (type IV) tapes with this unit.

NOTE

For the sake of simplicity, we refer to the tape side facing you as "side A" and to the tape side facing away as "side B" in this manual.

When you insert a cassette with "side A" and "side B" reversed, read "side A" as "side B" and "side B" as "side A".

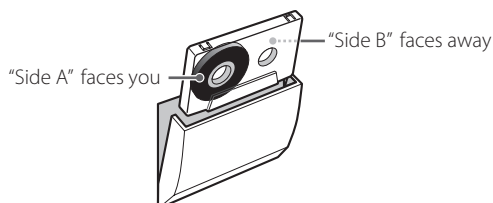

1 Press the SOURCE button repeatedly to select "TAPE".

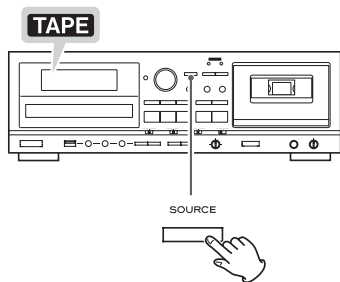

- When a different source is selected, starting tape playback automatically selects the tape.

2 Press the TAPE EJECT (▲) button to open the cassette tape compartment.

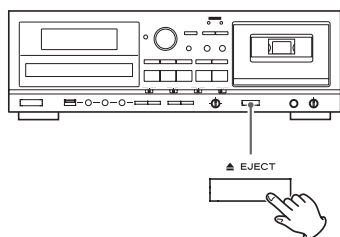

3 Put a cassette tape in the compartment.

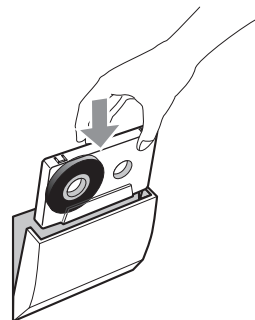

Insert the cassette tape with its open edge facing down and the side that you want to play facing you. Then, close the cassette compartment by pushing its door in.

CAUTION



- Do not use deformed or slack cassette tapes.
- Do not force the door of the compartment by hand when opening it.

Failure to follow any of the above cautions could cause malfunction.

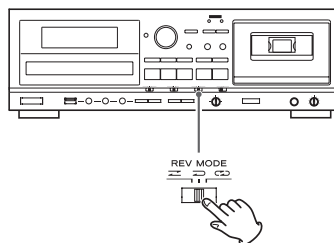
4 Set the reverse mode setting using the REV MODE switch.



You can select one of three settings.

-  **One way mode**
-  **Two way mode**
-  **Repeat mode**

5 Set the DOLBY NR (noise reduction) switch.

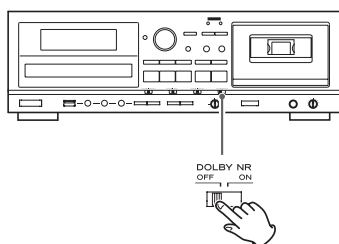

Set the switch to the ON position when playing back tapes recorded with Dolby NR.

To play tapes recorded without Dolby NR, set the switch to the OFF position.

About Dolby NR

Dolby NR is designed to reduce tape hiss, a noise introduced during the recording and playback processes. This cassette deck is equipped with Dolby B-type noise reduction.

6 Press the Reverse (◀) or Forward (▶) play button to start playback.

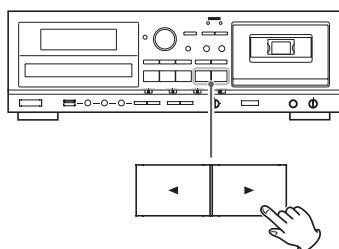

Forward (▶) play

Pressing this button starts playback of "side A".

When the reverse mode is set to 

Playback stops when the end of "side A" is reached.

When the reverse mode is set to 

Playback continues on "side B", stopping at the end of "side B".

When the reverse mode is set to 

Playback cycles through both tape sides 5 times.

Reverse side (◀) play

Pressing this button starts playback of "side B".

When the reverse mode is set to  or 

Playback stops when the end of "side B" is reached.

When the reverse mode is set to 

"Side B" is played back, and then playback cycles through both tape sides 4 times.

Pausing playback temporarily

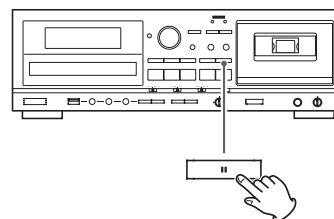

Press the TAPE Pause (||) button during playback to stop playback at the current position.

To resume playback, press the TAPE Pause (||) button again or press the Reverse/Forward play (◀ or ▶) button.

Stopping playback

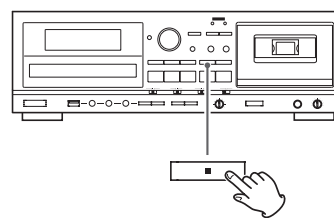

Press the TAPE Stop (■) button to stop playback.

Opening the cassette tape compartment

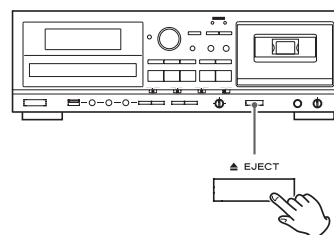

When the tape is stopped or paused, press the TAPE EJECT (▲) button to open the cassette tape compartment.

- You can also open the compartment when a source other than TAPE is selected.

Listening to a Cassette Tape (2)

Fast-forwarding/Rewinding a tape

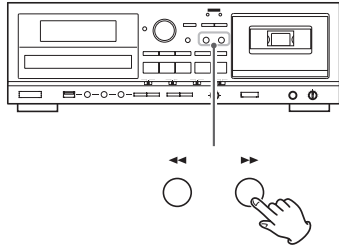

Press the Rewind (◀◀) button or the Fast-forward (▶▶) button to wind the tape rapidly.

Winding stops when the end of the tape is reached. To stop winding before the end, press the TAPE stop (■) button.

- You can wind the tape when CD/USB/LINE is selected as a source. These buttons do not, however, function when in a recording mode.

Pitch control

This control varies the pitch of the music during playback.

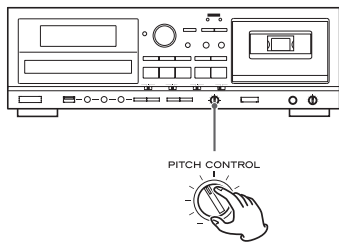

Turning the PITCH CONTROL knob clockwise increases the playback speed and raises the pitch by a maximum of +10%.

Turning the PITCH CONTROL knob counterclockwise reduces the playback speed and lowers the pitch by a maximum of -10%.

- This control does not work during recording.

Tape counter

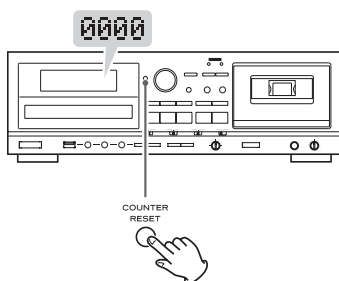

Press the COUNTER RESET button to reset the tape counter to "0000". You can use this function to easily locate any desired point on the tape.

About Recording

CD-R and CD-RW

A CD-R disc can be recorded only once. Recorded tracks cannot be erased. However, if some recordable time is still available, additional recording is possible. If you finish recording and finalize the CD-R disc, it can be played with a normal CD player. (Some CD players may not be compatible.)

On a CD-RW disc, even if no recordable time is available, you can erase tracks already recorded and record tracks repeatedly. You can erase all tracks at once or the last track only. However, you cannot erase only tracks in the middle of the disc.

If you finish recording and finalize the CD-RW disc, it can be played with a normal CD player. (page 36). Only CD players that support CD-RW discs can do so.

If you want to record again on a finalized CD-RW, unfinalize it (page 37). By unfinalizing (reversing the finalization), you will be able to record and delete tracks on the CD-RW again.

CD-RW discs can only be played with compatible CD players.

Serial Copy Management System

This unit is in compliance with the Serial Copy Management System standard. This standard has been established to restrict digital-to-digital copying to only the first generation. The basic rules governing this system are as follows:

Rule 1

A digital recording is possible from a digital source such as a CD, DAT or MD onto a recordable CD-R, CD-RW, MD or DAT through a digital input connection. However, further digital-to-digital recording is prohibited for the second and later generations.

Rule 2

When an analog source such as an analog disc or FM broadcast is digitally recorded by using a CD-R, CD-RW, MD or DAT, this recorded source can be digitally recorded on another CD-R, CD-RW, MD or DAT. However, further digital copying is prohibited.

Before Recording

Before you start recording, make sure that you understand the following points:

- Up to 99 tracks can be recorded according to the CD standards. When a 100th track is about to be recorded, recording will stop automatically.
- A track less than 10 seconds in length on an audio CD cannot be recorded.
- When recording is finished, "PMA WRITE" blinks for a few seconds, and then the unit goes into the stop mode. Do not apply shock or vibration to the unit while recording or "PMA WRITE" blinks.
- When the available recording time reaches 0, recording will stop automatically.
- If a half-way recorded disc is inserted, recording continues next to the last recorded track.
- You can add tracks to an unfinalized recordable disc. Once finalized, a CD-R disc is "fixed" and behaves in the same way as a CD. Finalized CD-RW discs, however, can be unfinalized, erased and re-recorded.
- When the auto track function is used, the tracks are separated based on the specified level. Therefore, if a silent part is contained at the beginning or in the middle of a track, the playback time may not be the same as the actual length of the track.
- When track numbers are added to continuous music such as live performances, the sound is cut a moment.
- If a disc recorded with this unit is played with another player, noises may occur when the track changes.

Auto track level

Sound level to detect "silence" to add track numbers using auto track when recording from external devices via ANALOG or to perform synchronous recording for digital sources such as CD, MD, and DAT.

This instruction manual describes "silence" as the situation where the recording source level is lower than the specified auto track level.

−60, −50, −40, and −30 dB can be selected.

Recording on a CD (1)

1 Load a recordable CD-R or CD-RW disc into the unit.

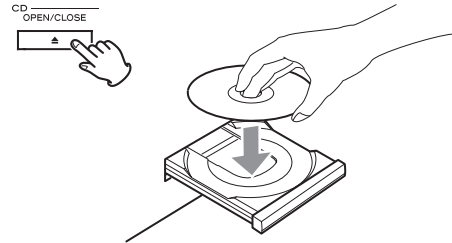

Press the OPEN/CLOSE (▲) button, place a disc on the disc tray with the disc label side up, and then press the OPEN/CLOSE (▲) button to close the disc tray.

Make sure "NO TOC" and "CD-R" (or "CD-RW") indicators light on the display.

2 Select the source to be recorded using the INPUT SELECT button. (TAPE, LINE IN, PHONO or DIGITAL)

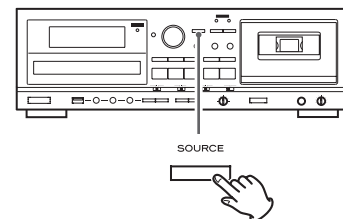

- The input source cannot be changed during recording.
- You cannot record from USB to CD.

3 Press the RECORD button (● RECORD).

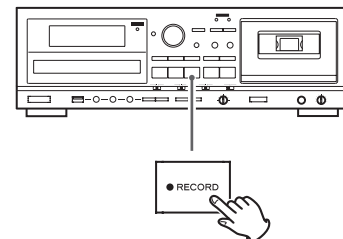

The red CD RECORD indicator to the right of the display and the **REC** indicator on the display blink.

- No button will work while "WAITING" is displayed. Wait a few seconds until "WAITING" disappears from the display. When DIGITAL is selected in step 2, the sampling frequency of the digital source (**DIGITAL**) ("FS 44_1K", "FS 48K" or "FS 32K") briefly appears after "WAITING".
- "OPTICAL UNLOCK" appears when the unit cannot perceive the digital signal. In that case, connect a digital device to the DIGITAL IN terminal, switch it on, and wait a few seconds until the unit enters the record pause mode.
- If you cannot record even if you press the CD record button (● RECORD), load a recordable disc. Confirm that "NO TOC" and "CD-R" (or "CD-RW") appears on the display and press the CD record button (● RECORD) again.

Recording on a CD (2)

4 Select the mode of track number assignment using the AUTO button.

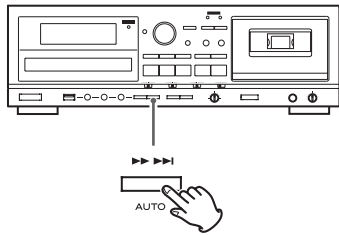

When the AUTO button is pressed once, the current auto track level is displayed. Press the AUTO button repeatedly to select another setting.

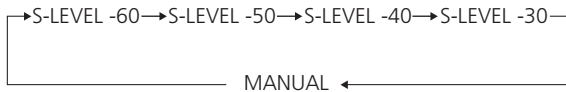

- After 2 seconds have passed, the display returns to the track/time display.

S-LEVEL-60/50/40/30 (The track numbers are automatically added)

The auto track function activates and "AUTO TRACK" appears. The displayed number indicates the auto track level.

The track numbers are automatically added during recording. If a track change is detected via DIGITAL, or if silence (lower than the auto track level) continues for three seconds or longer and then the next track starts (sound becomes louder than the auto track level) via ANALOG, the track numbers are automatically updated.

MANUAL (The track numbers are not automatically added)

In MANUAL mode, the track numbers are not automatically added. To add track numbers manually, press the RECORD button (● RECORD).

- The setting can be configured for DIGITAL and ANALOG respectively. When the power is turned on, the setting is -60 dB for DIGITAL, -50 dB for LINE IN, -40 dB for TAPE and -30 dB for PHONO IN.
- If the input source is changed, the S-LEVEL setting returns to the setting that had been set when the unit was turned on.
- If a CD is recorded via DIGITAL (**DIGITAL**), the track numbers are added based on the CD's digital signals. There is usually no need to change the auto track level.
- In digital recording, even if the auto track function is activated, track numbers may not be added depending on the digital source player. In such a case, add track numbers manually (see page 34).
- When you record digital broadcasts or other sources without track numbers, track numbers are not added even if the auto track function is activated. To add a track number, press the RECORD button (● RECORD) while recording a track.
- When you record classical music or other sources containing silent parts via ANALOG, track numbers may not be properly added even if the auto track function is activated. To add a track number in this case, deactivate the auto track function, and press the RECORD button (● RECORD) while recording a track.

- When you record a record or other sources with much interference, more track numbers than expected may be added unintentionally.
- The AUTO button cannot be used during recording.

If track numbers are not properly added

When you record sources with interference via ANALOG, track numbers may not be added if the auto track level is lower than the interference level. In this case, set the auto track level higher than the interference level.

If there is little interference and the track starts with a small sound resulting in the beginning of the recorded track being truncated, set the auto track level lower.

Noise	Quiet ←————→ Loud			
Examples	CD, MD			Record, cassette tape
S-LEVEL	-60	-50	-40	-30

5 (When recording from a tape, LINE IN or PHONO) Adjust the recording level.

Before recording, adjust the recording level. Failure to do so could cause the recorded sound to be distorted or noisy.

1. Play the source (cassette tape or external device) to be recorded.
2. Use the REC LEVEL knob to adjust the recording level so that the loudest sound never lights the "OVER" indicator on the peak level meter.

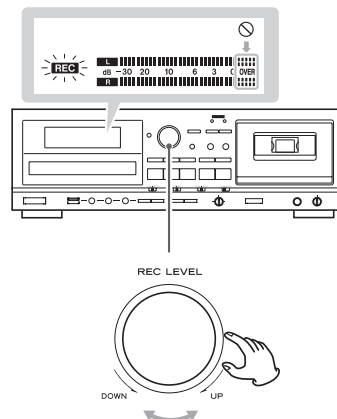

- Different sources to be recorded have different volumes. In order to record at the optimal volume for each source, it is necessary to adjust the recording level for each source.
- You cannot adjust the recording level when recording from a DIGITAL source.

6 Prepare the recording source.

Recording from a cassette tape

To record the entire tape, rewind the tape to its starting point. To record from the middle of a tape, stop or pause at the point from where you want to start recording.

Select the DOLBY NR (noise reduction) setting (page 10).

To record from a single tape side, set the REV MODE switch to , and set the playback direction using the Reverse (◀) or Forward (▶) play button. Then press the TAPE Stop (■) button.

To record from both tape sides, set the REV MODE switch to , and set the playback direction to ▶. If you set the recording direction to ◀, recording will be of "side B" only.

7 Press the CD Play/Pause (▶/||) button or RECORD button (● RECORD) again to start recording.

When recording from an external source, you must also start playback of that source.

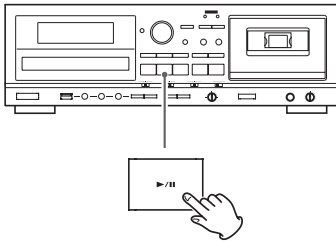

The red CD RECORD indicator to the right of the display and the **REC** indicator on the display stop blinking.

⚠ CAUTION

Do not turn the unit off or disconnect the power cord during recording. Doing so could damage the unit and connected devices.

- If the CD runs out of capacity during recording, recording will stop.
- To pause recording temporarily, press the CD Play/Pause (▶/||) button. A second press of the button resumes recording. Each time that you pause recording a new track number will be added.

Recording from a cassette tape

When source playback stops, recording also automatically stops. To stop recording, press the CD Stop (■) button. Doing this also stops playback of the recording source.

Recording from an external source

When source playback stops, recording does not automatically stop. Press the CD Stop (■) button to stop recording.

To stop recording

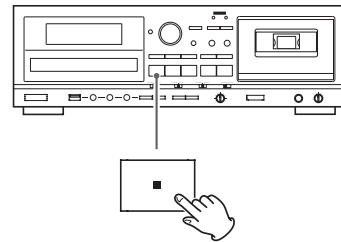

Press the Stop (■) button to stop recording.

- If the CD-R is finalized, it can be played with another CD player.
- If you finalize a CD-RW, it will become playable on other CD players that are compatible with CD-RW discs. If you want to record again on a finalized CD-RW, unfinalize it (page 37).
- The minimum length of a track that is required for recording is 10 seconds. If you press the Stop (■) button within 10 seconds from the beginning of a track, recording stops only after the track is recorded for 10 seconds.

To pause recording

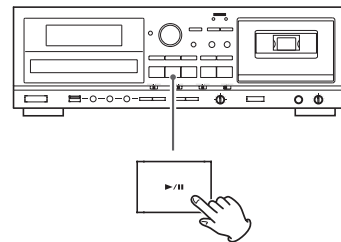

Press the CD Play/Pause (▶/||) button. "WAITING" briefly appears on the display, then recording is paused. To restart recording, press the CD Play/Pause (▶/||) button.

- You cannot restart recording while "WAITING" is displayed.
- Remember that every time recording is paused or stopped, a new track number will always be assigned. It is not possible to record in two "stages" within one track.

Recording on a CD (3)

Manual track division

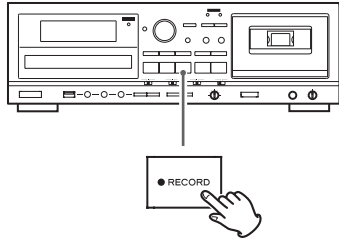

It is possible to divide a track into multiple tracks by pressing the RECORD button (● RECORD) while recording.

- Manual track division is possible regardless of the AUTO setting.
- A track cannot be less than 10 seconds in length. The RECORD button (● RECORD) will not work if it is pressed within 10 seconds from the beginning of a track.

Synchronous recording to CD

The convenient synchronous recording function automatically starts recording when receiving analog or digital signals from an externally connected device such as a CD player and MD deck, and stops recording when signal reception is complete.

For CD, MD, or DAT

Synchronous recording starts when a digital signal is detected, which is the beginning of a track. Synchronous recording stops if there is a period where the sound is quieter than the specified auto track level lasting five seconds.

For digital sources other than the above or analog sources

Synchronous recording starts when a sound louder than the specified auto track level is detected. Synchronous recording stops if there is a period where the sound is quieter than the specified auto track level lasting 8 seconds.

1 Complete steps 1 to 5 in "About Recording" to make the settings, and press the CD stop button (■).

- Since the recording level cannot be adjusted when the recording source is the digital input (DIGITAL), skip steps 4 and 5

2 Press the SYNC button and select "SYNC 1" or "SYNC ALL".

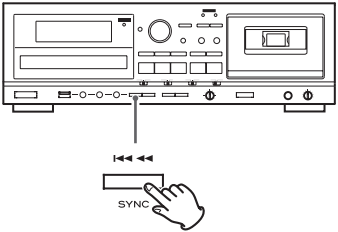

Each time you press the sync recording button (SYNC), the sync recording will change.



Select one of three modes.

ALL
Sync recording of all tracks.

ONE
Sync recording of one track and then recording stops.





OFF
No sync recording.



3 Prepare the recording source.

Recording from a cassette tape

To record the entire tape, rewind the tape to its starting point. To record from the middle of a tape, stop or pause at the point from where you want to start recording.

Select the DOLBY NR (noise reduction) setting (page 10).

To record from a single tape side, set the REV MODE switch to , and set the playback direction using the Reverse () or Forward () play button. Then press the TAPE Stop () button.

To record from both tape sides, set the REV MODE switch to , and set the playback direction to . If you set the recording direction to , recording will be of "side B" only.

4 Press the RECORD button (● RECORD).

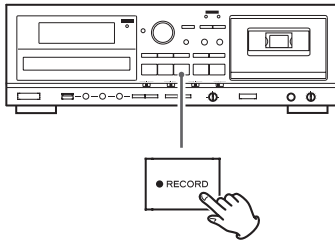

The red CD RECORD indicator to the right of the display and the **REC** indicator on the display blink.

- No button will work while "WAITING" is displayed. Wait a few seconds until "WAITING" disappears from the display. When DIGITAL is selected in step 2, the sampling frequency of the digital source (**DIGITAL**) ("FS 44_1K", "FS 48K" or "FS 32K") briefly appears after "WAITING".
- "OPTICAL UNLOCK" appears when the unit cannot perceive the digital signal. In that case, connect a digital device to the DIGITAL IN terminal, switch it on, and wait a few seconds until the unit enters the record pause mode.
- If you cannot record even if you press the CD record button (● RECORD), load a recordable disc. Confirm that "NO TOC" and "CD-R" (or "CD-RW") appears on the display and press the CD record button (● RECORD) again.

5 Start playing the source.

Sync recording will start.

If no sound is heard for 8 seconds or longer during synchronous recording, recording stops. To record the music with such periods of silence, turn off synchronous recording. After turning off synchronous recording, start recording manually, then play the source to be recorded.

- Press the Stop () button to stop the recording manually.
- The synchronous recording function automatically turns off after recording.
- The syn recording mode (one track or all tracks) cannot be changed during recording or in the record pause mode.
- If you select SYNC ALL, AUTO TRACK will be enabled, and the automatic track level will be set to -60 dB (-50 dB for analog signal input). Use the AUTO button to select the AUTO TRACK level.
- Even if the AUTO button is set to MANUAL, the auto track function will be on during synchronous recording. The auto track level is set to -60 dB (-50 dB when recording via ANALOG). The setting automatically returns to MANUAL after the recording.
- In digital recording, synchronous recording may not start depending on the digital source player. In such a case, start and stop recording manually.
- Depending on the source, silence could be detected, causing recording to stop in the middle of a track or the beginning to be cut off. If this occurs, set AUTO TRACK to MANUAL and record manually.

Finalizing

Finalizing is the addition of TOC (recorded data information) to discs.

If you finalize a CD-R, it will become playable on other CD players. Finalized CD-R discs cannot be used for additional recording.

If you finalize a CD-RW, it will become playable on other CD players that are compatible with CD-RW discs

1 Press the input SOURCE button and select CD mode.

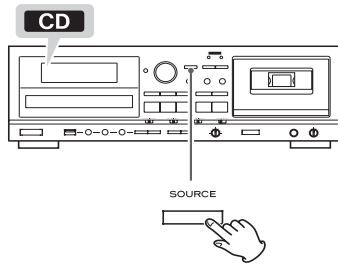

2 Load an unfinalized (recordable) disc.

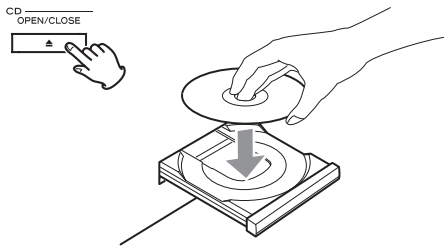

3 Press the FINALIZE/ERASE button in the stop mode.

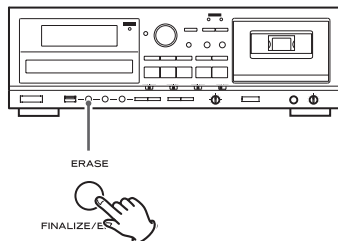

Press the FINALIZE/ERASE button once.
"FINALIZE" appears on the display.

- If "UNFINALIZE" appears on the display, the disc is already finalized and so finalization is unnecessary.
- To cancel the operation at this point, press the stop button (■).

4 Press the CD Play/Pause (▶/||) button to start finalizing.

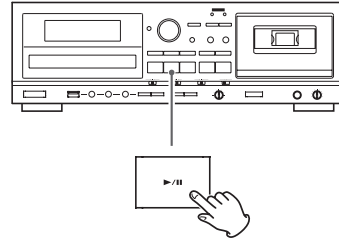

Finalization starts.

When finalization completes, the display will show "COMPLETE" briefly before returning to its ordinary appearance (total number of tracks and total playback time).

- Never turn the power off nor unplug the power cord during finalization.
- During finalization, no button works.

Unfinalizing (CD-RW only)

If you want to record again on a finalized CD-RW, unfinalize it. By unfinalizing (reversing the finalization), you will be able to record and delete tracks on the CD-RW again.

1 Press the input SOURCE button and select CD mode.

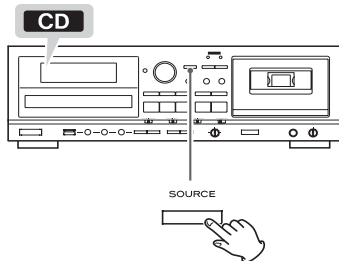

2 Load a finalized (recordable) disc.

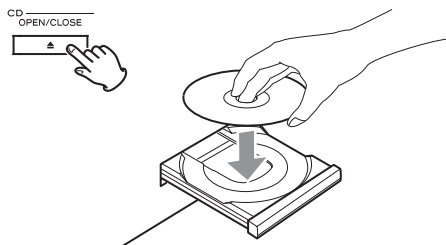

3 Press the FINALIZE/ERASE button in the stop mode.

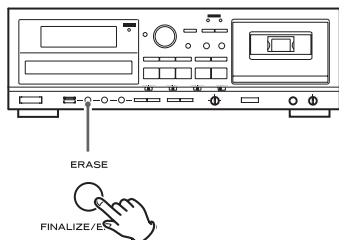

Press the FINALIZE/ERASE button once. "UNFINALIZE" appears on the display.

- If "FINALIZE" appears on the display, the disc is not finalized, so unfinalization is unnecessary
- To cancel the operation at this point, press the stop button (■).

4 Press the CD Play/Pause (▶/||) button to start unfinalizing.

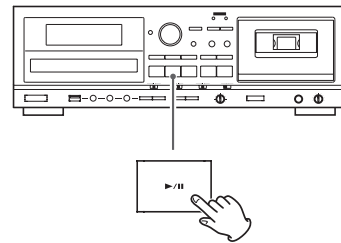

Unfinalization starts.

When unfinalization completes, the display will show "COMPLETE" briefly before returning to its ordinary appearance (total number of tracks and total playback time).

- Never turn the power off nor unplug the power cord during unfinalizing.
- During unfinalizing, no button works.

Erasing tracks from a disc (CD-RW only)

1 Press the input SOURCE button and select CD mode.

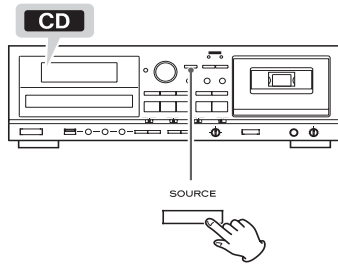

2 Load a CD-RW that has not been finalized or has been unfinalized.

- If you load a finalized disc, "UNFINALIZE" will appear. You must unfinalize the disc before you can erase tracks on it (page 37).

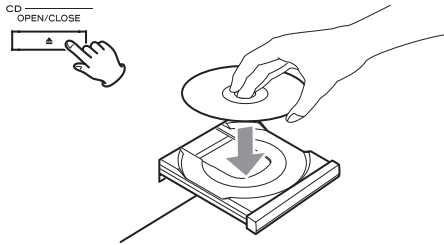

3 Press the FINALIZE/ERASE button in the stop mode.

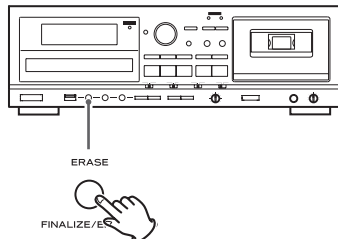

- Each time the ERASE button is pressed, the display changes as follows:

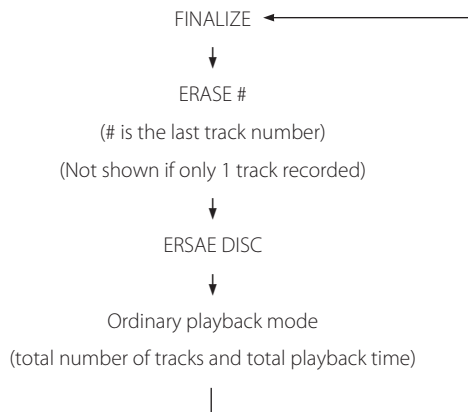

- If a finalized disc is loaded, "UNFINALIZE" is displayed. Because a finalized disc cannot be erased, you need to unfinalize it first (page 36).

Erasing the last track

Press the FINALIZE/ERASE button until "ERASE" and the last track number appear on the display.

- You can also erase all the tracks from the currently selected track number to the last track at once. To do this, use a skip (⏮ or ⏭) button to select the track from which you want to start erasing. (You cannot erase only certain tracks before the last track.)

Erasing all tracks (ordinary mode)

- Press the FINALIZE/ERASE button until "ERASE DISC" appears on the display.

4 Press a CD Play/Pause (▶/⏸) button to start erasing.

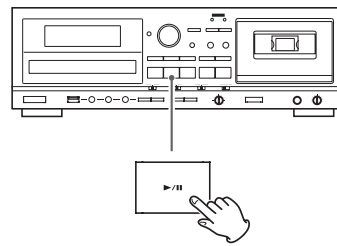

The track(s) will be erased.

After erasure completes, the display will return to its ordinary appearance (total number of tracks and total playback time).

- Do not turn off the power or disconnect the power cord during erasure.
- During erasure, buttons will not function when pushed.
- Erasure cannot be undone! Be sure that you want to erase the contents of a CD before starting.

Recording on a USB Flash Drive (1)

Using this unit, the contents of CDs, cassette tapes and audio input from other devices by the LINE IN, PHONO jacks and DIGITAL IN terminal can be converted to MP3 format and recorded on USB flash drives.

- This unit can also record to CDs and cassette tapes, but it cannot simultaneously record to these media and USB flash drives.
- Timer recording cannot use CD or USB recording media.

⚠ CAUTION

Do not disconnect the USB flash drive during recording. Do not turn the unit off or disconnect the power cord during recording. Doing so might cause damage to the AD-RW900 and the connected USB flash drive.

About recorded MP3 files

- When recording, a "RECORD" folder is automatically created and a subfolder for each source ("CD", "TAPE" or "LINE") is also created in the "RECORD" folder. MP3 files are added to the corresponding subfolder.
- File names are assigned automatically with a numerical endings in order.

When recorded from a CD

"CD001.MP3", "CD002.MP3" ...

If there are, for example, files named "CD004.MP3" and "CD009.MP3" in the USB folder already, and you make a recording, the next new file will be named "CD010.MP3".

- If you start recording a track/file that has already started playing, the elapsed time of the track/file being recorded that appears on the display will be the same as the elapsed time of the current track that is also shown on the display.

When recorded from a cassette tape

"T001.MP3", "T002.MP3" ...

When record from an external source

"L001.MP3", "L002.MP3" ...

- During recording from tape or external source input, you can divide the file manually (page 41). In this case, consecutive numbers are added to the ends of the file names.

Example:

For example, if you manually divide "T001.MP3" during recording, the new track names will be "T001.MP3" and "T002.MP3".

- This unit can record up to 999 files to a USB device. However, if the USB device already contains files, those files will be included in the maximum total of 999 files when recording.
- The recordable time for one file is less than 600 minutes.
- Tracks recorded onto a USB flash drive are converted to MP3 files at a bit rate of 128 kbps.

1 Insert a USB flash drive into the unit's USB port.

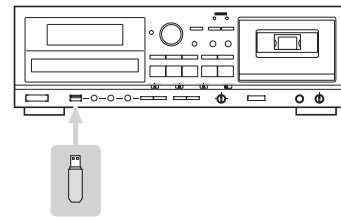

- You cannot record to an external USB flash drive if there is no free space or the device is write-protected.
- Before recording, check the remaining capacity of the USB flash drive using a PC. You cannot check the remaining memory capacity with this unit.

2 Press the SOURCE button repeatedly to select the source to be recorded (CD, TAPE, or LINE).

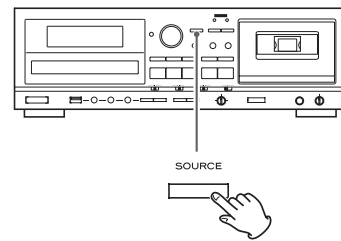

3 Press the RECORD USB button to start recording standby.

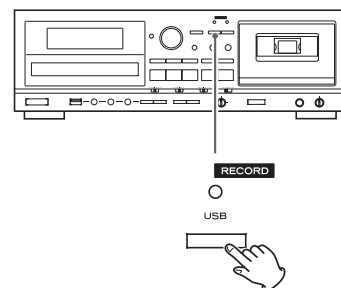

The red indicator above the RECORD USB button and the **REC** icon on the display blink.

- To stop recording, press the USB Stop (■) button.

Recording on a USB Flash Drive (2)

4 (When recording from a tape, LINE IN or PHONO) Adjust the recording level.

Before recording, adjust the recording level. Failure to do so could cause the recorded sound to be distorted or noisy.

1. Play the source (cassette tape or external source) to be recorded.
2. Use the REC LEVEL knob to adjust the recording level so that the loudest sound never lights the "OVER" indicator on the peak level meter.

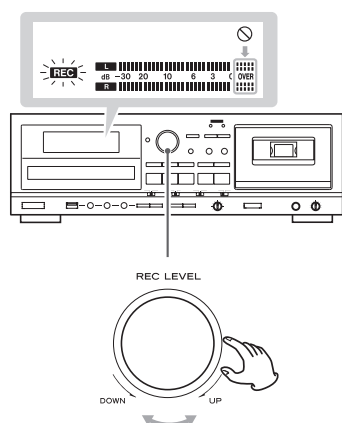

- Different sources to be recorded have different volumes. In order to record at the optimal volume for each source, it is necessary to adjust the recording level for each source.
- You cannot adjust the recording level when recording from CD or DIGITAL source.

5 Prepare the recording source.

Recording from CD

To record all the tracks/files on a CD, stop the disc first. To record only some of the tracks/files on a CD, pause at the beginning of the part that you want to record.

You can also record tracks in programmed order. For information about how to set the program, see pages 25-27.

Recording from cassette tape

To record the entire tape, rewind the tape to its starting point. To record from the middle of a tape, stop or pause at the point from where you want to start recording.

Select the DOLBY NR (noise reduction) setting (page 10).

To record from a single tape side, set the REV MODE switch to , and set the playback direction using the Reverse (◀) or Forward (▶) play button. Then press the TAPE Stop (■) button.

To record from both tape sides, set the REV MODE switch to , and set the playback direction to ▶. If you set the recording direction to ◀, recording will be of "side B" only.

Recording from an external source

Prepare to start playback of the source device.

- Example:** Set the source selection of an amplifier.
Set the playback media in a connected player.
To record from a tuner, tune in a station.

6 Press the RECORD USB button again to start recording.

When recording from an external source, you must also start playback of that source.

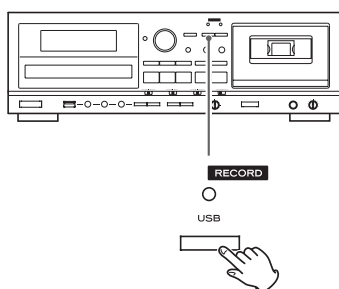

The red indicator above the RECORD USB button and the **REC** icon on the display stop blinking.

⚠ CAUTION

Do not turn the unit off or disconnect the power cord during recording. Doing so could damage the unit and connected devices.

- If the USB flash drive runs out of free space during recording, recording stops automatically.
- To pause recording temporarily, press the USB Play/Pause (▶/⏸) button. A second press of the button resumes recording. A new track number will be assigned if you pause and restart recording.

Recording from CD or cassette tape

When source playback stops, recording also automatically stops. To stop recording, press the USB Stop (■) button. Doing this also stops playback of the recording source.

Recording from an external source

When source playback stops, recording does not automatically stop. Press the USB Stop (■) button to stop recording.

Manually dividing files

(adding track numbers during recording)

When you are recording from a tape or device connected to the LINE IN or PHONO jacks or recording from such a device has been paused, you can press the RECORD USB button to divide the recording into tracks and create new file names.

Dividing tracks takes about a few seconds.

You cannot manually divide tracks when recording from CDs. (When recording from a CD, tracks are divided automatically.)

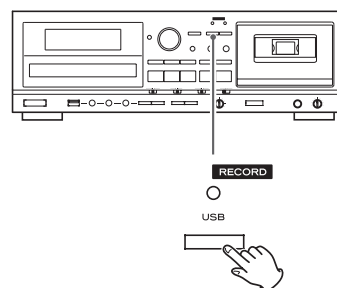

When recording from the LINE inputs:

During file division, a gap will be left in the recording.

- This unit cannot divide an already recorded MP3 file. This function only works during recording.
- Consecutive numbers are added to the end of the file names after division.

Example:

If you manually divide "T001.MP3" during recording, the new track names will be "T001.MP3" and "T002.MP3".

Erasing Files from a USB Flash Drive

⚠ CAUTION

Do not disconnect the USB flash drive during erasing. Do not turn the unit off or disconnect the power cord during erasing. Doing so might cause damage to the AD-RW900 and the connected USB flash drive.

Erasing a file

1 Start playing the file that you want to delete (page 22).

2 Press the ERASE button.

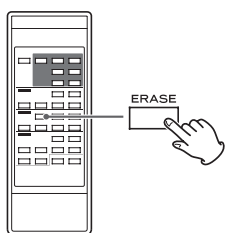

"Erase file?" appears on the display.

3 Within 6 seconds, press the ERASE button again.



"Erasing" appears on the display, the file currently being played is erased, and playback stops.

Recording on a Cassette Tape (1)

Using this unit, the contents of CDs, USB flash drives and audio input from other devices by the LINE IN and PHONO jacks or the DIGITAL IN terminal can be recorded on cassette tapes.

You can record on Normal (type I) and Chrome (type II) tapes with this unit. Recording on Metal (type IV) is not supported by this unit.

- You can record on a single or on both sides of the tape.
- This unit can also record to CDs and USB flash drives, but it cannot simultaneously record to these media and cassette tapes.

1 Put a cassette tape in the compartment.

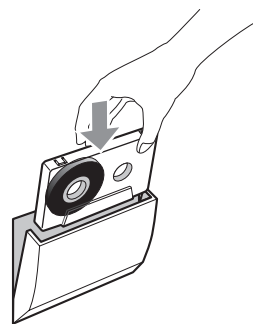



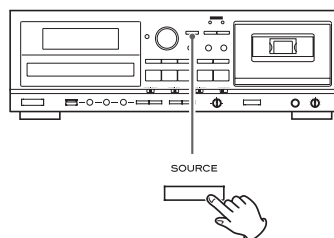

- If the erasure prevention tabs of the cassette tape have been broken off, cover the holes using pieces of adhesive tape.



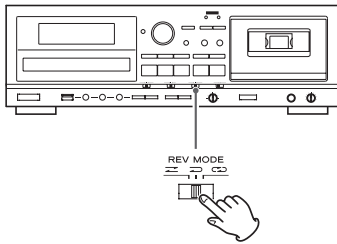

2 Press the SOURCE button repeatedly to select the source to be recorded (CD, USB, LINE IN, PHONO or DIGITAL).



3 Set the reverse mode setting using the REV MODE switch, and set the recording direction.



To record on a single tape side, set the REV MODE switch to , and set the recording direction using the Forward () or Reverse () play button. Then press the TAPE Stop () button.

To record on both tape sides, set the REV MODE switch to  or , and set the recording direction to . If you set the recording direction to , only "side B" will be recorded on.

4 Set the DOLBY NR (noise reduction) switch to ON or OFF.

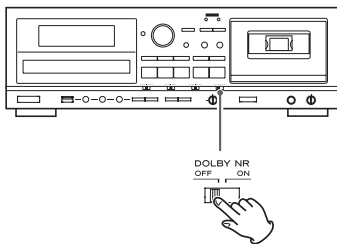

For information about the DOLBY NR function, see page 10.

5 Press the RECORD TAPE button to enter recording standby mode.

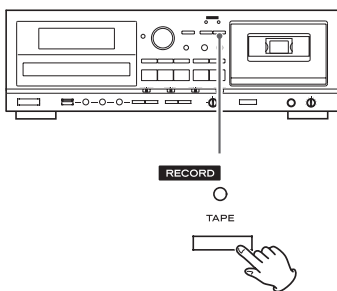

The red indicator above the RECORD TAPE button and the **REC** icons on the display blink.

- To stop recording, press the TAPE Stop () button.

6 Adjust the recording level.

Before recording, adjust the recording level. Failure to do so could cause the recorded sound to be distorted or noisy.

1. Play the source (external source) to be recorded.
2. Use the REC LEVEL knob to adjust the recording level so that the loudest sound does not continually exceed the "0" indicator on the peak level meter.

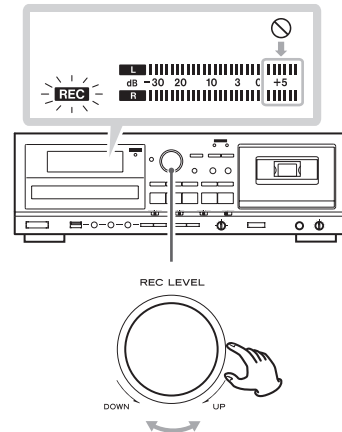

- Different sources to be recorded have different volumes. In order to record at the optimal volume for each source, it is necessary to adjust the recording level for each source.

7 Prepare the recording source.

Recording from CD

To record all the tracks/files on a CD, stop the disc first. To record only some of the tracks/files on a CD, pause at the beginning of the part that you want to record.

You can also record tracks in programmed order. For information about how to set the program, see pages 25-27.

Recording from USB flash drive

To record the entire contents of the USB device, put the unit into stop mode. To record from the middle of the USB device, pause at the point from where you want to start recording.

You can also record tracks in programmed order. For information about how to set the program, see pages 25-27.

- See page 50 for information about the playback order of MP3 files.

Recording from an external source

Prepare to start playback of the source device.

Example: Set the source selection of an amplifier.
Set the playback media in a connected player.
To record from a tuner, tune in a station.

Recording on a Cassette Tape (2)

8 Press the RECORD TAPE button again to start recording.

When recording from an external source, you must also start playback of the source.

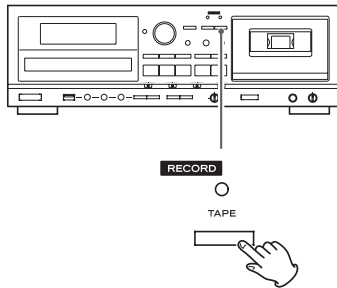

The red indicator above the RECORD TAPE button and the **REC** icon on the display stop blinking.

⚠ CAUTION

Do not turn the unit off or disconnect the power cord during recording. Doing so could damage the unit and connected devices.

- To stop recording temporarily, press the TAPE Pause (⏸) button. Press the button again to resume recording.

Recording from CD or USB flash drive

When source playback stops, recording also automatically stops. To stop recording, press the TAPE Stop (■) button. Doing this also stops playback of the recording source.

- During auto-reverse recording to a tape, if "side A" of the tape ends in the middle of a track/file while recording from a CD or USB device, the unit starts recording again on "side B" from the beginning of the track/file that had been interrupted.

Recording from an external source

When source playback stops, recording does not automatically stop. Press the TAPE Stop (■) button to stop recording.

Erasing recordings

With every new recording, the contents of a cassette tape will be overwritten (the previous recording is erased). You can erase a cassette tape by setting the recording level to MIN to record silence.

- We recommend that you select a source for recording that does not output any sound during the erasing process.

1 Press the TAPE RECORD (● RECORD) button to start recording standby.

2 Set the REC LEVEL control to the minimum position (MIN).

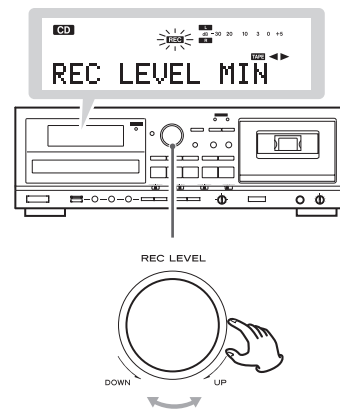

3 Press the Reverse (◀) or Forward (▶) play button to start erasing (by recording silence).

Timer-Controlled Playback and Recording (1)

Connecting a commercially available timer to your audio setup lets you wake up to your favorite music or start recording at specified times.

- The source for timer playback must be CD, TAPE or USB. Timer playback does not work with external devices connected to the LINE inputs.
- The timer recording source can only be an external device connected to the LINE inputs. And the timer recording can only record to cassette tape.

Connections

Referring to the illustration below, connect your audio equipment.

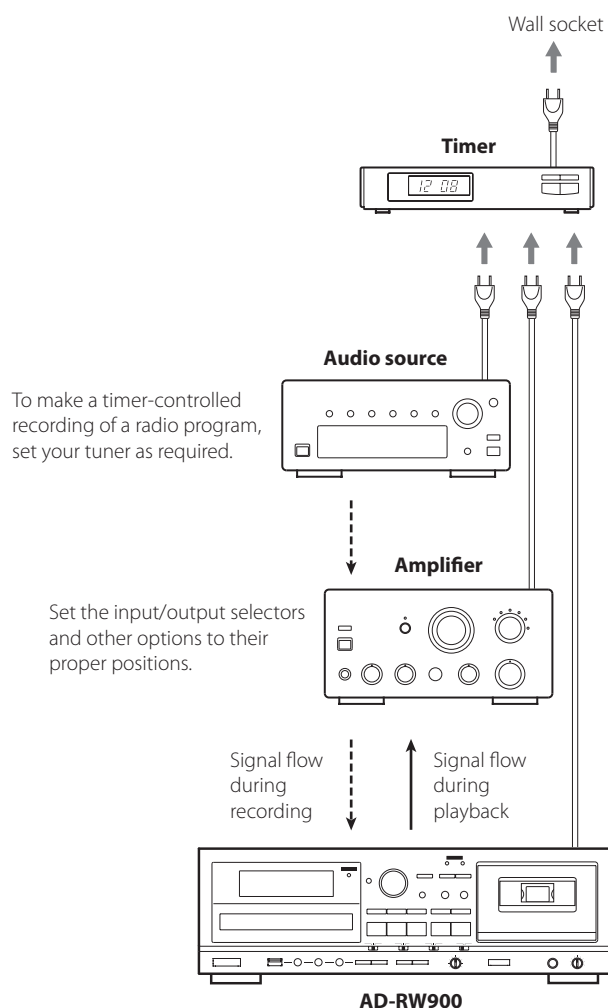

⚠ Turn off the power of all equipment before making connections.

- Read the instructions of each component you intend to use with this unit.
- Be sure to connect each plug securely. To prevent hum and noise, do not bundle the connection cords.

Timer-Controlled Playback (**CD** **USB** **TAPE**)

- The source for timer playback must be CD, TAPE or USB. Timer playback does not work with an external device connected to the LINE input.

1 Connect this unit and a stereo system to a commercially available audio timer (see previous page).

Make sure that the outlet that the timer is plugged into is receiving power when it is being used.

2 Set the power switch of all components to ON.

3 Prepare the source for timer playback.

When you set a cassette tape

- ➔ Set the REV MODE switch to the desired position. To make both sides play continuously, set the REV MODE switch to the position.
 - ➔ Set the DOLBY NR switch. (page 10).
- Playback always starts from "side A".

4 Set the CD-TAPE-USB switch to the desired source for timer playback.

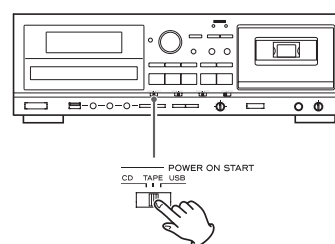

5 Set the OFF-PLAY-REC switch to the PLAY position.

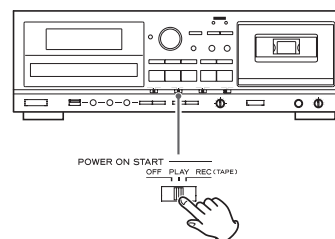

"TIMER" appears on the AD-RW900's display.

Continued on the next page ➔

Timer-Controlled Playback and Recording (2)

- 6** Set the audio timer to your desired start (power on) and stop (power off) times.

When this setting is completed, the power to all components should be turned off.

At this time, do not press the AD-RW900 POWER button. Leave the button pushed in (the on position). If the POWER button is in the off position, timer playback will not function.

When the preset start time is reached, power will be supplied and playback will start automatically.

- When you do not want to use the timer, set the OFF-PLAY-REC switch to the OFF position.

Timer-Controlled Recording (LINE → TAPE)

- The timer recording source can only be an external device connected to the LINE inputs. And the timer recording can only record to cassette tape.
- The recording level is set to 0 dB; it cannot be adjusted.

(Example: Recording a broadcast program)



- 1** Connect this unit and a stereo system to a commercially available audio timer (see previous page).

- 2** Set the power switches of all components to ON.

- 3** Prepare the cassette tape that you want to record to with timer recording.

Recording always starts from "side A".

To record on a single tape side, set the REV MODE switch to .

To record on both tape sides, set the REV MODE switch to  or .

Set the DOLBY NR switch (page 10).

If the erasure prevention tabs of the cassette tape have been broken off, cover the holes using pieces of adhesive tape.

You can record on Normal (type I) and Chrome (type II) tapes with this unit.

NOTE

If you have previously used the cassette, and the tape is stopped part of the way through "side B" of the cassette, timer recording will then start part of the way through "side A". Always bear this in mind, so that you do not accidentally erase any important recordings. You should take special note of this when recording more than once on the same cassette using the timer recording function.

4 Set the CD-TAPE-USB switch to TAPE.

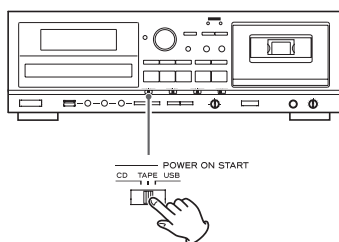

- This unit cannot record to CDs and USB flash drives with the timer recording.

5 Set the OFF-PLAY-REC switch to the REC position.

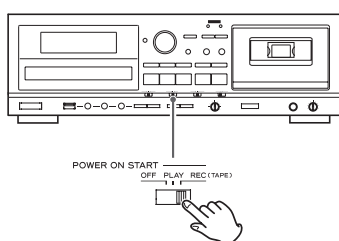

"TIMER" and **REC** appear on the AD-RW900's display.

6 Tune in the station that you want to record (when recording from radio).

7 Set the audio timer to your desired start (power on) and stop (power off) times.

When this setting is completed, the power to all components will be switched off.

At this time, do not press the AD-RW900 POWER button. Leave the button pushed in (the on position). If the POWER button is in the off position, timer recording will not function.

When the preset start time is reached, power will be supplied and recording will start automatically.

- When you do not want to use the timer, be sure to set the OFF-PLAY-REC switch to the OFF position to prevent accidentally recording over an important cassette tape.

Recording to a Computer

Connection illustration

AD-RW900 (Back side)



On its rear panel, this unit has a USB port for the output of audio signals. When connected to a computer by USB cable, this unit can convert audio signals to digital data and send it to the computer.

- Use a commercially available cable to make the connection.

Connecting with a computer

1 Turn the computer power on.

Confirm that the OS has started properly.

2 Connect this unit to a computer using a USB cable.

3 Press the POWER button to turn the unit on.

When the computer and this unit are connected, the computer should automatically detect this unit's USB port and recognize it as "USB Audio CODEC".

Selecting the recording source

This unit will send the audio being played back to the computer. Press the SOURCE button to select the playback source (page 19).

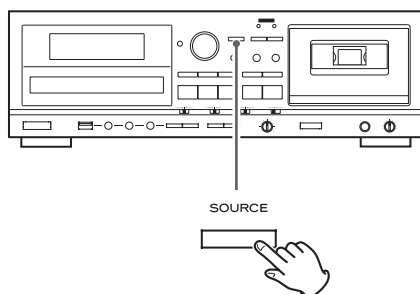

Adjusting the recording level

When connected to a computer by USB, use the REC LEVEL knob to adjust the level of the audio data sent to the computer.

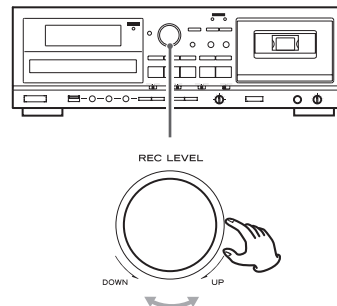

Check the computer recording software or the signal from this unit being played back by the computer, and use the LEVEL knob to increase the level so that it is as loud as possible without distortion.

- Even when connected to a computer by USB, the REC LEVEL knob also adjusts the recording level when in recording standby and during recording.
- If the recording level can also be adjusted by the computer recording software that you are using, set its recording level approximately to the center position of the provided scale before adjusting the level sent by this unit.
- Avoid the following things when connected to a computer by USB and recording audio because they could cause the computer to malfunction. Always quit the computer recording software before doing any of the following.
 - Disconnecting the USB cable
 - Turning this unit off

Troubleshooting (1)

If you experience any problems with this unit, please take the time to read through these pages and see if you can solve the problem yourself before you call your dealer or a TEAC service center. Moreover, the problem might be caused by something other than this unit. Confirm that connected devices are also being used properly.

General

No power

- ➔ Check the connection to the AC power source. Confirm that the AC source is not a switched outlet, and, if it is, that the switch is turned on. Confirm that there is power to the AC outlet by plugging another device such as a lamp or a fan into the outlet.

Remote control does not work

- ➔ Press the POWER button of the main unit to turn it on.
- ➔ If the batteries are exhausted, change the batteries.
- ➔ Use the remote control within its effective range (16 ft/5 m) and point it toward the remote sensor on the front panel.
- ➔ Make sure that there are no obstacles between the remote control and the main unit.
- ➔ If a fluorescent light is near the unit, turn it off.

Other devices with remote controls operate incorrectly

- ➔ Other devices with remote controls might operate incorrectly because of infrared light "overspill" when you operate the remote control of this unit. If that is the case, use the control buttons on this unit instead of on the remote control to operate the AD-RW900.

Buttons do not work properly

- ➔ If another operation is still in process, wait a moment and try again.

No sound or only a very low sound level is heard

- ➔ Check the connections to the amplifier.
- ➔ Check that the speakers and other audio components are connected securely.
- ➔ Check the operation of the connected component.
- ➔ There might be a ⊕/⊖ short in a speaker cable. Check the speaker cables.
- ➔ Select the correct input source using the SOURCE button.

Severe hum or noise is heard

- ➔ Place the unit as far away from TVs as possible.
- ➔ Do not bundle audio cables with speaker cables or power cord.

CD Recorder

Will not play

- ➔ Load a disc with the label side up.
- ➔ If the disc is dirty, clean the surface of the disc. If the disc is scratched or has any sticky substance on its surface, do not play the disc until you have corrected the condition of the disc. Never under any circumstances use after-market stick-on labels or "disc enhancement" devices that sit on top of or wrap around a disc.
- ➔ If a blank disc has been loaded, load a prerecorded disc.

- ➔ Depending on the disc and other factors, playback of some CD-R/RW discs might not be possible. Try again with another disc.
- ➔ You cannot play unfinalized CD-R/RW discs. Finalize such a disc in a CD recorder and try again.
- ➔ If moisture condensation has occurred inside of the unit, leave the unit for one or two hours with the power turned on.

Sound skips

- ➔ Place the unit in a stable place to avoid vibrations and shocks.
- ➔ If the disc is dirty, clean its surface.
- ➔ Do not use scratched, damaged or warped discs.

Recording is not possible.

- ➔ A playback-only disc or finalized disc has been loaded. Use a recordable disc.
- ➔ The recording level is too low. Adjust the recording level.
- ➔ The remaining recording time of a CD-R is not sufficient. Use another disc.
- ➔ If the remaining recording time of a CD-RW is not sufficient, erase the last tracks or replace the disc.
- ➔ Synchronous recording does not start if the sound coming in is quieter than the auto track level.

The numbers and lengths of tracks differ from those of the original tracks.

- ➔ The unit recognizes the beginning of a track by detecting the auto track level of sound. The track number may not be applied to the silent part.

Cassette tape recorder

Cassette tape compartment does not close

- ➔ The cassette tape is not properly loaded. Reinsert it.



Sound quality is poor

- ➔ Clean the heads (page 6).
- ➔ If a head is magnetized, demagnetize it with a head demagnetizer.
- ➔ Check that the Dolby NR switch is set to the same position as when the recording was made.

Playback speed seems somewhat fast or slow

- ➔ Check the pitch control setting (page 30).

Auto reverse does not occur

- ➔ Set the REV MODE switch to  or .
- ➔ If the REV MODE switch is set to , start playback from the tape side facing you ("side A").

Cannot record

- ➔ If the erasure prevention tabs on top of the cassette are broken off, cover the holes using pieces of adhesive tape.
- ➔ Check the recording level setting (page 44).

Continued on the next page ➔

Troubleshooting (2)

USB

No sound even if the USB Play/Pause (▶/II) button is pressed

- Confirm that there are MP3 files on the USB device.
- File formats other than MP3 (e.g. MPEG 1 LAYER 2 file) and WMA cannot be played.

Cannot record

- Confirm that the USB flash drive has free space.
- Confirm that the USB flash drive is not locked.
- When record from an analog source, check the recording level setting (page 40).

MP3/WMA files

Unknown characters are displayed on the display

- This unit cannot display double-byte symbols and characters (such as Japanese and Chinese) correctly. MP3 file names must only be alphanumeric characters to be shown properly.

MP3 files

“Title No” (title information unavailable), “Artist No” (artist information unavailable) or “Album No” (album information unavailable) appears on the display

- ID3 tag information for the music file is missing. Edit the title, artist and/or album information of the song on a PC using a suitable application.

Since this device uses a microcontroller, external noise and other interference can cause the unit to malfunction. If this occurs, turn the power off and, after waiting for about one minute, restart operation.

MP3 Playback Order

MP3 files on a CD or a USB flash drive can be stored in folders in the same way that files are managed on a computer. Moreover, multiple folders can be contained inside another folder.

Here is an example of the file and folder structure of an MP3 disc or a USB flash drive, showing the order of the folders (001 “ROOT” to 005) and the playback order of the files (1 to 9).

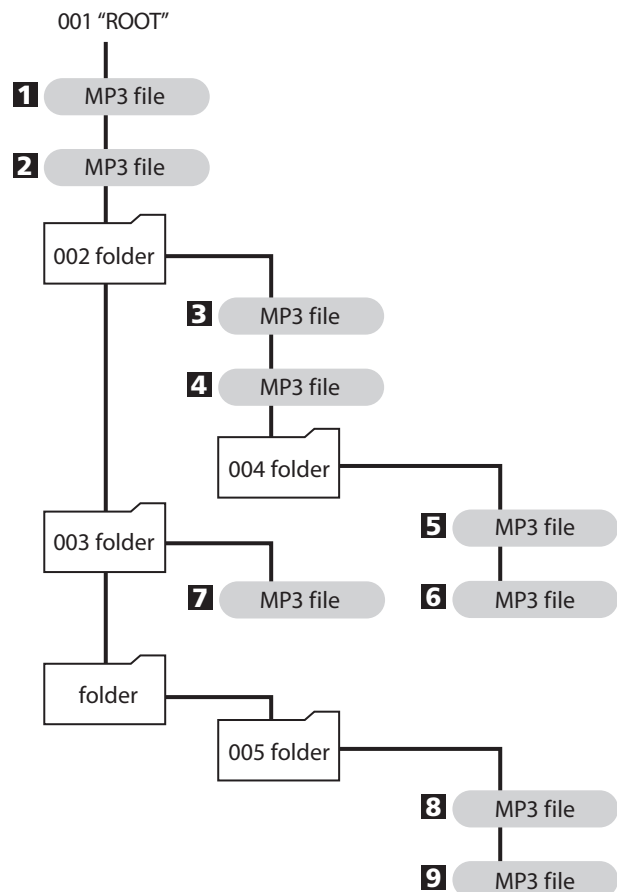

Specifications

CD recorder

Pickup	3-beam, semiconductor laser
Recording media	CD-R/CD-RW discs for music
Recording sampling frequency	44.1 kHz
Frequency response	20 Hz–20 kHz (during playback: ± 1.5 dB, during recording/playback: ± 2.0 dB)
S/N ratio	.90 dB or higher (during playback) 90 dB or higher (during digital recording/playback) 80 dB or higher (during analog recording/playback)
Dynamic range	.86 dB or higher (during playback) 86 dB or higher (during digital recording/playback) 78 dB or higher (during analog recording/playback)
Total harmonic distortion	0.05% or lower (during playback) 0.05% or lower (during recording/playback)
Analog output	2.0 V (RCA)

Cassette deck

Track format	4-track, 2-channel stereo
Head structure	recording/playback head $\times 1$ (reversible) Erasure head $\times 1$
Tape type	C-60 cassette tape
Tape speed	4.76 cm/sec
Motor	DC servomotor $\times 1$
Pitch control	about $\pm 10\%$ (playback only)
Wow and flutter	0.25% (W.RMS)
Frequency response (total)	chrome: 50–12,000 Hz ± 3 dB normal: 50–12,000 Hz ± 3 dB
S/N ratio (total)	59 dB (Dolby NR off, 3% THD level WTD) 69 dB (Dolby NR on, 5 kHz or higher)
Winding time	about 150 sec (C-60 tape)
Line input (RCA)	0.46 V (input impedance 20 k Ω or higher)
Line output (RCA)	0.46 V (load impedance 50 k Ω or higher)
Headphone output	10 mW/32 Ω

PHONO input

Input sensitivity	2.5 mV, 47 k Ω
-------------------	-----------------------

Digital audio input

Input sampling frequency	32, 44.1, 48 kHz
--------------------------	------------------

USB

USB port (A-type)

Playable MP3

Supported standard	MPEG-1/2 Audio Layer-3
File name extension	“.mp3”
Sampling frequency	32, 44.1, 48 kHz
Bit rate	8–320 kbps
Maximum number of folders	255
Maximum number of files	999

Playable WMA

Supported standard	Windows Media Audio Standard (DRM not compatible)
File name extension	“.wma”

Recording format (MP3)

Recording bit rate	128 kbps
Sampling frequency	44.1 kHz

USB port (B-type) $\times 1$

General

Power	AC 230 V, 50 Hz (Europe/UK Model) AC 120 V/230 V, 50–60 Hz (General Export Model)
Power consumption	28 W
Dimensions (W x H x D)	435 x 145 x 288 mm (including protrusions)
Weight	5.6 kg (12 1/3 lb)
Operating temperature range	+5° C to +35° C
Operating humidity range	5–85% (no condensation)
Storage temperature range	–20° C to +55° C

Included accessories

Remote control (RC-1283)	$\times 1$
Remote control batteries (AAA)	$\times 2$
RCA audio cable	$\times 2$
Owner's manual (this document)	$\times 1$
Warranty card	$\times 1$

- Specifications and appearance are subject to change without notice in order to improve the product.
- Illustrations in this manual might differ in some aspects from the actual model.

TEAC

TEAC CORPORATION	1-47 Ochiai, Tama-shi, Tokyo 206-8530 Japan	Phone: (042) 356-9156
TEAC AMERICA, INC.	7733 Telegraph Road, Montebello, California 90640 U.S.A.	Phone: (323) 726-0303
TEAC CANADA LTD.	5939 Wallace Street, Mississauga, Ontario L4Z 1Z8, Canada	Phone: (905) 890-8008
TEAC MEXICO, S.A. DE C.V.	Río Churubusco 364, Colonia Del Carmen, Delegación Coyoacán, CP 04100, México DF, México	Phone: (5255) 5010-6000
TEAC UK Ltd.	Suites 19 & 20, Building 6, Croxley Green Business Park, Hatters Lane, Watford, Hertfordshire, WD18 8TE, U.K.	Phone: (0845) 130-2511
TEAC EUROPE GmbH	Bahnstraße 12, D-65205 Wiesbaden-Erbenheim, Deutschland	Phone: 0611-71580

This device has a serial number located on its rear panel. Please record the serial number and retain it for your records.

Model name: AD-RW900 Serial number: _____

1011·MA-1728A